

Shot Peening

Designer's guide to the process, its applications,

DEVELOPED in the late twenties, shot peening was discovered by accident. A small batch of automobile valve springs behaved much better than expected under test. Investigation revealed that they had been shot blasted to improve the surface. This discovery led to commercial development of the process, although up to the start of the second world war the process was confined almost exclusively to automotive parts such as springs, gears, and axles. During the war, pressing need for higher performance without increased weight caused rapid development of the shot-peening process.

Today in the automotive industry, all chassis and valve springs, and many gears and shafts,

are shot peened. Without shot peening, these parts would have to be 30 to 50 per cent heavier, increasing the weight of an automobile by as much as several hundred pounds. The weight savings made possible by use of shot-peened parts are of great importance in the aircraft industry for engine parts, propellers, landing gear, and similar items subject to repeated loading. Other industries requiring a high strength to weight ratio, such as the oil industry, also rely heavily on shot peening. An important recent development is shot peening of ultrahigh-strength steels for improved fatigue-life characteristics.

In its initial stages, shot peening was a more or less haphazard variation of shot blasting. It has

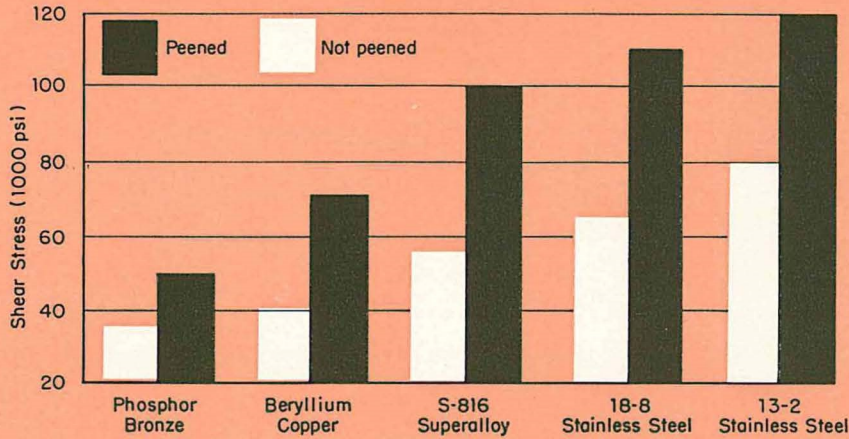

Fig. 1— Safe fatigue-life ranges for coil springs of various materials, indicating increased life available with shot peening

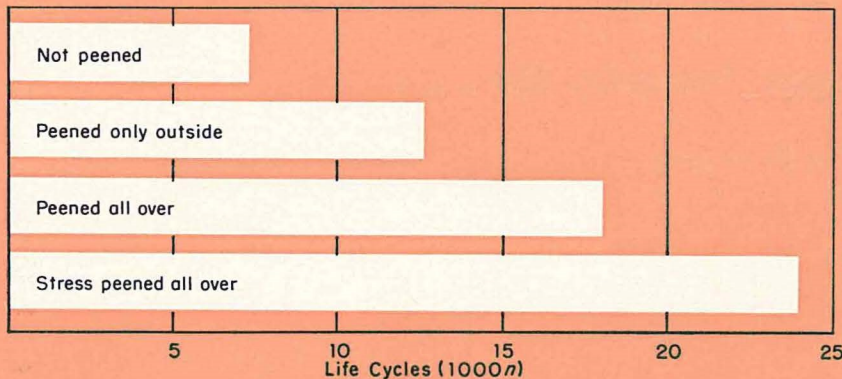

Fig. 2—Effect of different shot-peening treatments on fatigue life of latch springs

By **H. O. FUCHS** and **E. R. HUTCHINSON**

Metal Improvement Co.
Los Angeles, Calif.

its effects, and how and where to specify it.

now become exact, making it possible to issue standard specifications and obtain repeatable results.

Fatigue-Life Improvement

Principal use of shot peening is to increase fatigue life of cyclically stressed parts. The earliest application (and still largest in terms of volume) is spring treatment. Favorable results are obtained on coil springs in a great variety of materials. Fatigue-strength increase of 70 to 150 per cent can be expected from nonferrous or high-alloy

spring materials, Fig. 1; for steel springs, increases of over 70 per cent have been reported.¹ Leaf springs were among the early applications and considerable data are available.

Full improvement in spring life is obtained after a peening treatment of 2 minutes; further peening, up to 20 minutes, does not further improve the fatigue life. More significant improvements are obtained by peening springs while they are held in the strained or loaded position. For example, an actual improvement quoted (compared to a 5000-cycle life of an untreated spring) is 100,000 cycles for a peened spring and up to 1 million

¹References are tabulated at end of article.

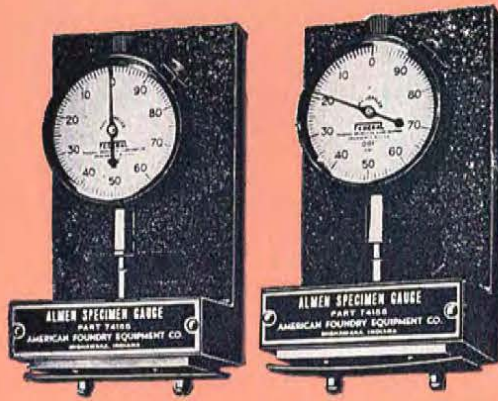

Fig. A—Almen peening-intensity gages checking curvature of un-peened (left) and peened (right) strips.

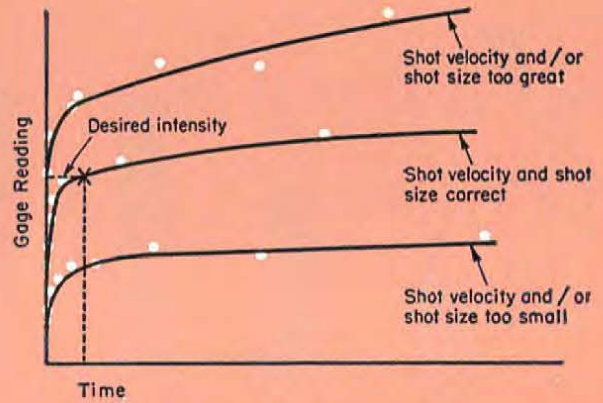

Fig. B—Increase of curvature of Almen test strip with increase in peening time.

Almen-Intensity Notation

Standard method of specifying shot-peening intensity is by Almen numbers. The numbers indicate the arc height (or curvature) of a steel strip which has been exposed on one side to the same shot-peening treatment as the part for which the treatment is specified. Such strips, Fig. A, are made of spring steel in two standard thicknesses—0.051 in. for A scale, 0.094 in. for C scale. Their standard hardness is Rockwell C 47 ± 3 .

Specification of an Almen intensity always implies that peening must be carried out to saturation. The arc height increases with time of peening up to a limiting value, Fig. B. The same arc height obtained by a shorter time of potentially more intense peening corresponds to a spotty distribution of residual stresses and to less increase in fatigue life.

Curvature of the test strip is used to measure intensity of the shot stream. In a peened strip, when b is the arc height in in. and c is the chord length in in., the bending moment, M , can be obtained by $M = 8EIb/c^2$ in.-lb, E and I being the modulus of elasticity and the moment of inertia of the section.

For a steel strip 0.075 wide by 0.051 in. thick, with b measured over a chord length of 1.25 in., this equation gives M as 1270 in.-lb; for a typical value of $b = 0.014$ in., this would be equivalent to a bending moment of 17.8 in.-lb.

In actual fact, the bending moment is produced by a layer that is a few thousandths of an inch in thickness, but to obtain some idea of the forces involved, the force F , the resultant of the residual stress, is considered to be concentrated on the surface. Then, $F = 2M/t$, where t is the thickness. In the example given, and converted to a strip-width of 1 in., $F = 935$ lb/in. Generally, for a deflection b of the test strip, the surface force per inch of width is $F = 66,000b$ lb.

Table 1—Recommended Peening Intensity for Steel

Thickness (in.)	Almen Intensity (A. Scale)
$\frac{1}{8}$ to $\frac{1}{4}$	0.003 to 0.009
$\frac{1}{4}$ to $\frac{3}{8}$	0.007 to 0.014
over $\frac{3}{8}$	0.012 minimum

cycles for a strain-peened spring.²

Localized peening may merely shift location of failure, as shown by a series of tests on a C-shaped spring, Fig. 2.³ Unpeened springs failed on the outside. When peened on the outside, they failed on the inside; peening all over resulted in increased life.

Spring life improvement is particularly important for aircraft springs. In one instance, replacement of an unpeened spring by a stress-peened spring resulted in a weight saving of over 40 lb, achieved by reduction in size of the spring and supporting parts.⁴

In addition to springs, many parts subject to

alternating stresses, particularly on aircraft equipment, are shot peened. Exhaust stacks, Fig. 3, have an odd shape and are thin material, yet improvement gained by shot peening is maintained even at working temperatures. Piston wrist pins are shot peened on the inside by special nozzles. Peening of axle shafts, Fig. 4, increases the endurance limit more than 100 per cent.⁵ Cold straightening is very damaging to the fatigue life, so shot peening is used to overcome these harmful effects.

Peening Hard Steel

Very interesting results are achieved by peening hard steel, Fig. 5. Without peening, fatigue strength reaches approximately 70,000 psi max at about Rockwell C 42 hardness.⁶ Fatigue strength of unpeened parts does not increase with increasing hardness, while fatigue strength of peened parts increases proportionately with hardness up to 140,000 psi at Rockwell C 53.^{6,7} By using shot-peened hard steels, the designer can achieve greater static and fatigue strengths without danger of brittleness.

Surface decarburization is a danger when using high-strength steel parts. Loss of fatigue strength, following even partial decarburization, is well known. Restoration of lost fatigue strength by shot peening is very effective. Up to 0.040 in. depth of partial decarburization on ultrahigh-strength steel

SHOT PEENING

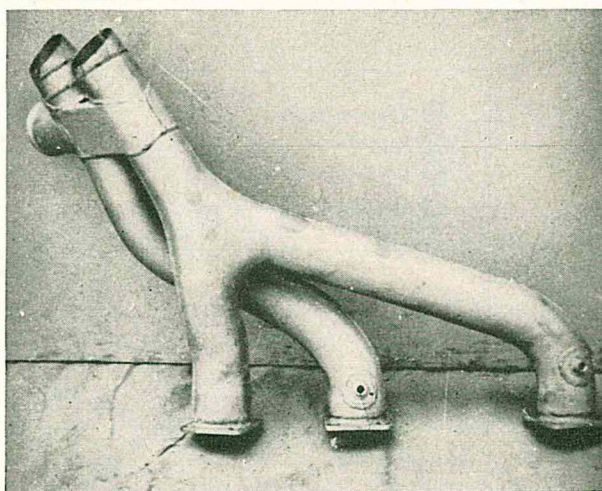
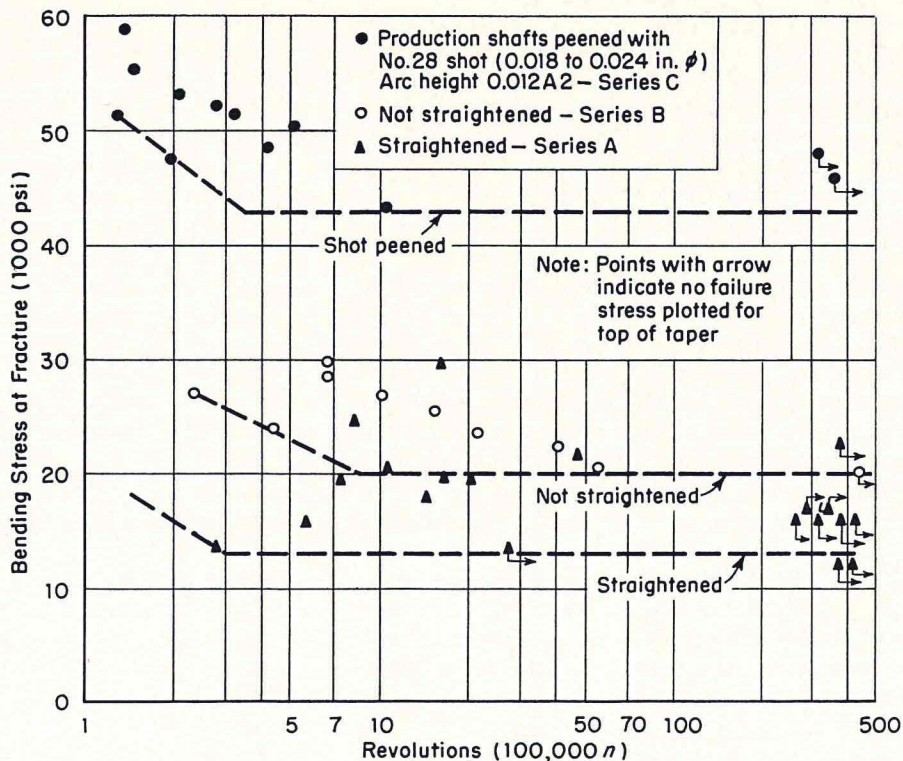

Fig. 3—Aircraft-engine exhaust stack, shot peened for improvement of fatigue life under alternating stresses at elevated temperatures

for landing gears is rendered harmless by shot peening, Fig. 6. Mozley states, "It appears safer to permit some decarburization and peen the part, rather than risk surface carburization".⁸ Further results are given by some fatigue tests on very hard springs, quenched to a hardness of Rockwell C 62 and not drawn, Fig. 7. Without peening, these springs had a very low fatigue life; with peening they lasted longer than peened springs of the highest commercial hardness.⁹

Fig. 4— Fatigue-test data for axle shafts, indicating effects of peening after straightening



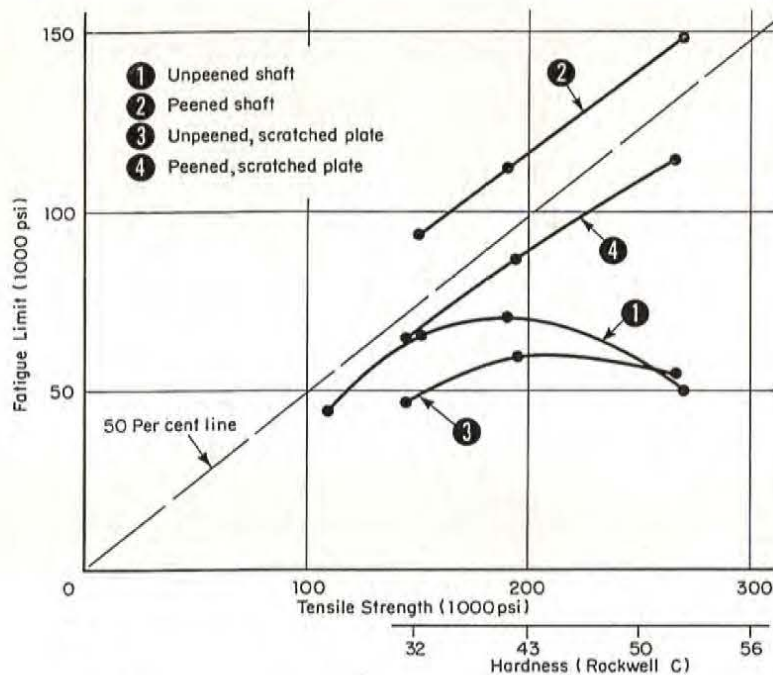

Fig. 5—Fatigue limit as a function of hardness for peened and unpeened specimens



Fig. 6—Aircraft landing-gear part of ultrahigh-strength steel is shot peened to overcome effects of decarburization

Shot peening is used successfully to overcome dangers of surface damage in vital components such as propellers.⁷ Steel specimens were shot peened and then hit by glass splinters to produce surface scratches about 0.005-in. deep. Fatigue limits of peened and unpeened parts, plotted over depth of the compressively stressed skin produced by peening, Fig. 8, show that prior peening maintains the fatigue limit of the part (even after surface damage has occurred) above the fatigue limit of the unpeened, undamaged part. Results of tests on specimens heat treated to various hardnesses, Fig. 5, follow the trend previously established, i.e., as steel hardness increases, effect of shot peening on fatigue strength becomes more pronounced. This effect is particularly noticeable with the higher hardness ranges.

Most applications of shot peening in the past were concerned only with increased fatigue durability. Shot peening can be used in a much wider field to obtain higher static strength, as well as better fatigue resistance, by application to steel parts that are so hard they would be brittle without peening. With further development of this technique, great savings of cost, as well as of weight and space, will result. Grossman showed that the brittle-transition temperature was 60 F lower and the permissible strain-rate 20 times higher on shot-peened specimens than on otherwise equal specimens without peening.¹⁰

Grinding may damage the fatigue life of hard materials. Extent of damage depends on severity of the grinding operation. By shot peening after

grinding, the damage can be entirely overcome and beneficial effects of shot peening achieved. Severe grinding with shot peening gives an endurance limit 40 per cent higher than gentle grinding without shot peening, while severe grinding alone lowers the endurance about 30 per cent below that of gentle grinding, Fig. 9.¹¹

Plating by itself or plating on ground surfaces, may also produce damage that can be completely overcome by peening before plating, Fig. 10.¹² Landing-gear parts, Fig 5, are chrome plated after shot peening so that cracks which form in the chrome do not propagate into the steel and cannot harm fatigue life of the part.

Effect of Peening

Benefits of shot peening result in part from work-hardening of susceptible material, such as stainless steel, but mainly from presence of residual compressive stresses produced by the treatment. If only one side of a sheet or strip is treated, the effect is readily visible because the compressed side tries to expand and, in doing so, bends the part. This bending induces a small compressive stress on the untreated side so that equilibrium of forces and bending moments in the cross section is established.

Careful removal of layers and observation of changes in curvature permit distribution of re-

residual stresses to be determined. Distribution of residual stress measured in this manner on shot-peened carburized steel, spring steel, and aluminum is shown in Fig. 11. Difference in intensity corresponds to difference in depth of the compressively stressed skin; peak stress and surface stress depend on the material—not on intensity. Peak stress slightly below the surface is typical of the distribution shown by many similar measurements. In general, on materials that do not strain harden substantially, maximum residual stress is around half the static yield strength of the material. Where strain hardening is a factor, residual stress may be higher and may depend on peening intensity. Residual stress will also be higher when peening is done with the material under strain. Residual stress can then reach the static yield strength of the material.

Relation Between Residual Stress and Fatigue Life: Theoretical explanation of benefits obtained by shot peening and similar treatments depends upon relation between residual stress and fatigue life. Since fatigue failures are cracks and cracks never open unless adjacent particles are pulled apart, it may be assumed that cracks cannot start in a compressed layer, nor propagate into it.

Detailed research shows to what extent this hypothesis is true.¹³ Results of fatigue tests, with the permissible-stress range plotted over the mean stress, indicate that the permissible-stress range increases in going from tensile average stress to compressive average stress, Fig. 12. Recent work based on best available test data, indicates fatigue is a function of alternating shear stress and average normal (compressive or tensile) stress, and that permissible range of alternating stress increases as average stress becomes more compressive and decreases as average stress becomes more tensile.¹⁴ This relation for tension and compression is shown in Fig. 13. Increase of permissible alternating stress, when the average stress is compressive, is

SHOT PEENING

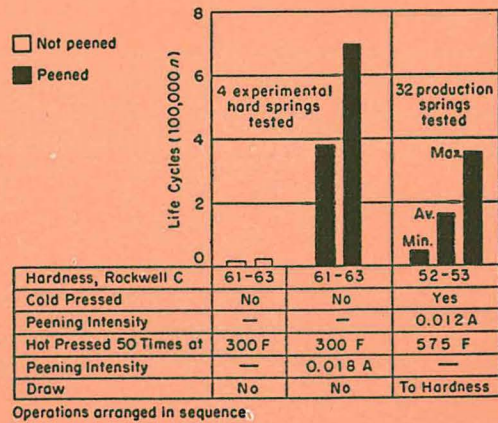

Fig. 7—Effect of shot peening on springs quenched to brittle hardness and not drawn

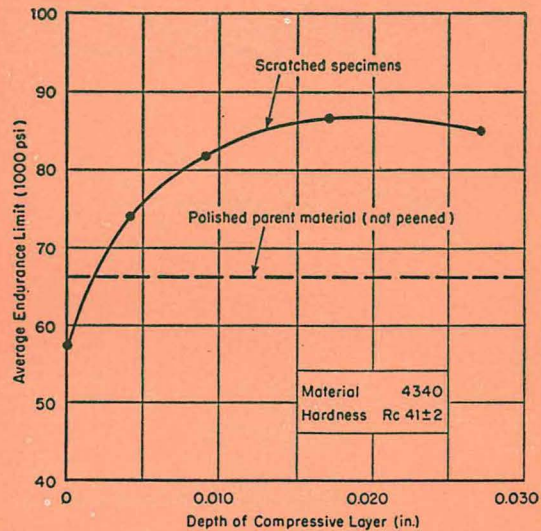
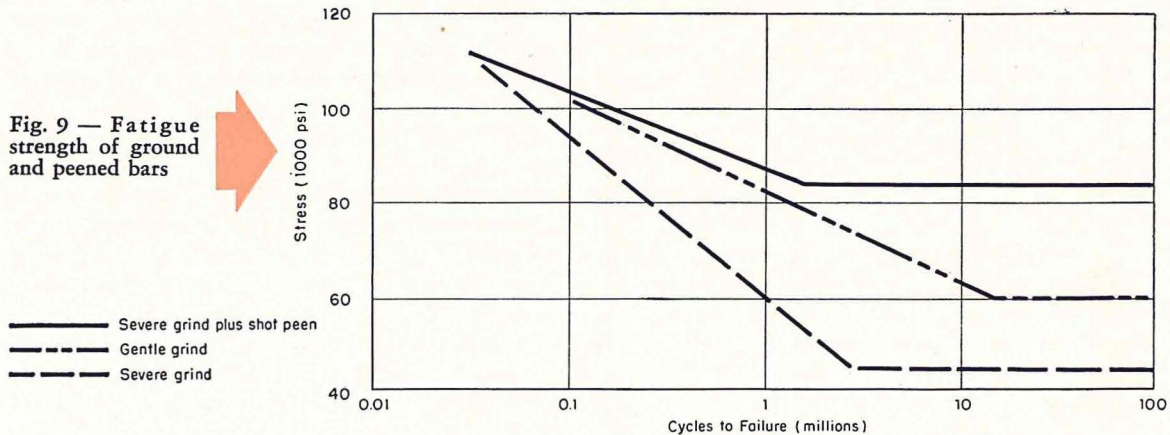

Fig. 8—Fatigue limit plotted against depth of compressive layer produced by peening. Specimens scratched after peening.

Fig. 9 — Fatigue strength of ground and peened bars



indicated by slope of the cross-hatched area upward on the compressive side and downward on the tensile side. This area encloses large numbers of test points taken from the most reliable of the test results.

Peening overcomes brittleness because plastic deformation necessary to produce small local adjustments can take place only if the shear stress has a value sufficiently high. Cracking will occur

when tensile stress reaches a limit value. Treatment must then permit a high shear stress with a low tensile stress—this is done by providing compressive prestress. The same stress acting inside a part is less dangerous than when it acts at the surface, because the surface is subjected to damaging influences from minute imperfections, traces of corrosion, cracks, and lack of cohesion.¹⁵

Yield Strength Effects: Residual stresses (like any other stresses) remain as long as total stress (load stress plus residual stress) has not exceeded yield strength. Yield strength for repeated loading is lower than the statically measured yield strength by 25 to 40 per cent, as shown by the well-known settling of springs, Fig. 14, and by published test data.^{16,17}

These considerations explain why shot peening and similar treatments based on residual stresses become less effective for higher ranges of alternating stress and must lose their effectiveness when the stress range reaches twice the dynamic yield strength. Under such conditions, residual stress would disappear and only the effect of strain hardening would remain. Testing will, therefore, fail to show benefits from peening if test stresses are appreciably higher than service stresses. Practical solution to such limitations is, of course, found by using material of higher yield strength, such as very hard steels.

Heat may lower yield strength and thus diminish or destroy effect of residual stresses. For spring steel tested at high stress ranges, benefit of shot peening remains fully effective up to 500 F and partially effective up to 800 F.¹⁸ For other materials and other stress ranges, results are different, depending on effect of temperature on dynamic yield strength.

Plastic Deformation from Peening: Residual stresses produced by shot peening result from plastic deformation produced by the shot striking the workpiece. Microphotographs of sections taken below an indentation indicate extent of plastic deformation taking place. Typical indentations of a large ball of soft steel are shown in Fig. 15 and 16.¹⁹ A considerable amount of cold working takes place; depth of cold-worked area is proportional to diameter of impression, regardless of depth or of ratio of depth to diameter. Cold-worked area extends sidewise away from center of indentation over a distance considerably exceeding diameter of indentation. The last two observations are important for specification of effective shot-peening treatment, regardless of material involved.

Surface roughness bears little relation to depth of worked layer—to achieve a certain minimum depth of worked surface layer, it is not necessary to have 100 per cent coverage on the surface, i.e., there may be some distance between one dimple and the next as long as this distance is less than the width to which plastic deformation extends. This fact explains why 100 per cent coverage by dimples is not absolutely necessary, although it is, of course, the safest objective. In a highly stressed surface,

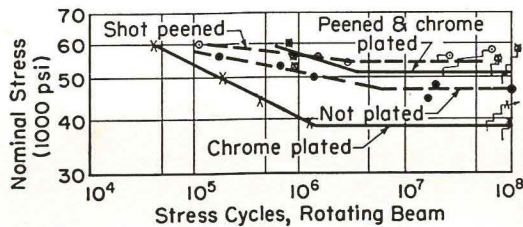

Fig. 10—Fatigue strength of chrome-plated steel, peened and unpeened

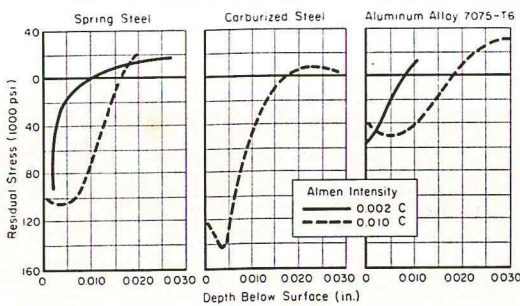

Fig. 11—Distribution of residual stress in spring steel, carburized steel, and aluminum

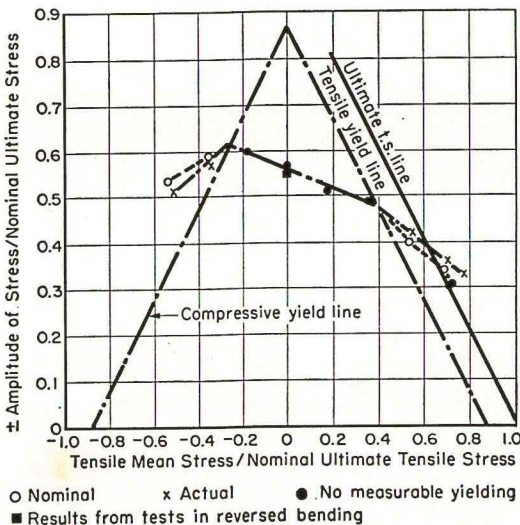

Fig. 12—Effect of mean stress on fatigue

unpeened areas of several dimple diameters will always become the origin of fatigue cracks.

Shot-Peening Specifications

Shot peening intensities can be measured easily and with a high degree of significance. The standard Almen test procedure, combined with applications of shot peening, has resulted in a series of official specifications for the process.²⁰ Specifications should stipulate intensity of peening for a given section thickness, details and tolerances of shot to be used, inspection procedure, and subsequent or prior treatments.²¹

Choice of Intensity: Peening intensity for steel is given by specifications in Table 1. Generally, minimum required intensity should be chosen, because higher intensities can only be achieved at higher cost. Thin sections can be damaged by excessive peening intensity. For general applications, an intensity of 0.010 to 0.014 A will be satisfactory. To some extent, intensity is also dictated by shape of the part; projecting edges may be damaged by too great an intensity, particularly on very hard or carburized materials.

For steel springs, equal Almen intensities give equal increases in fatigue life, regardless of shot size or material. This is probably also true for other parts made of steel in the hardness range of rockwell C 35 to 55. For much softer materials, this does not hold true. For instance, if the velocities of soft shot and of hard shot are adjusted to have equal effects on Almen strips, on aluminum the soft shot at the higher velocity will produce a deeper layer of compressive stresses.²² If the velocities of large and of small shot are adjusted to have equal effects on Almen strip, on aluminum the large shot at lower velocity will produce a deeper compressed skin.²³

To allow for these differences without forcing

SHOT PEENING

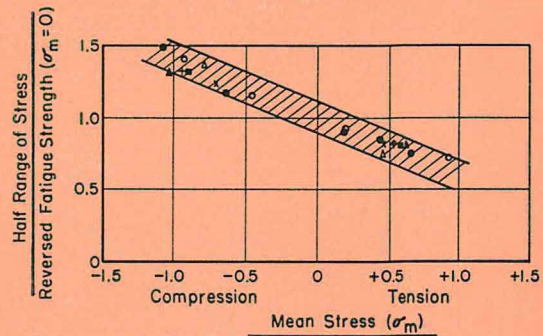

Material	Yield Strength	
	Fatigue Strength	Yield
x 2024 Aluminum	± 26,000 psi	48,000 psi
o 0.41 C Steel	± 36,000	55,000
+ 0.65 C Steel	± 38,000	57,000
Δ 0.44 C Steel	± 33,000	57,000
● Duralumin	± 17,000	32,000
■ Mild Steel	± 26,000	38,000
▲ Mild Steel	± 37,000	47,000

Fig. 13—Effect of normal stress on permissible alternating shear stress (endurance range)

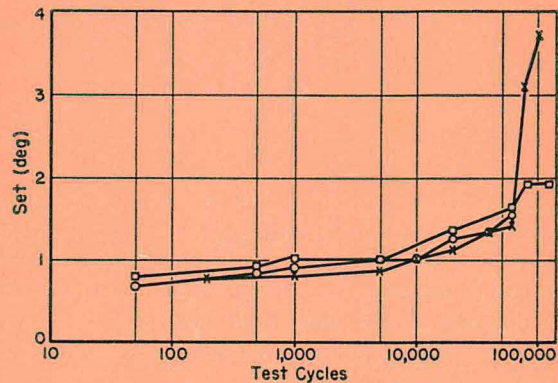

Fig. 14—Settling of coil springs during fatigue testing

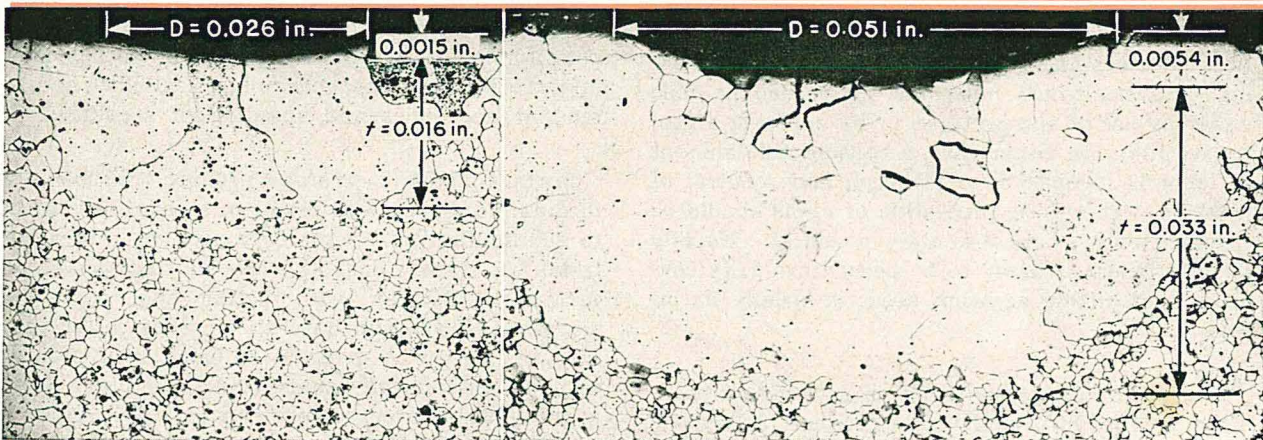

Fig. 15—Microphotograph of grain growth under shallow indentation made by 1/4-in. ball

Fig. 16—Microphotograph of grain growth under deep indentation made by 1/4-in. ball

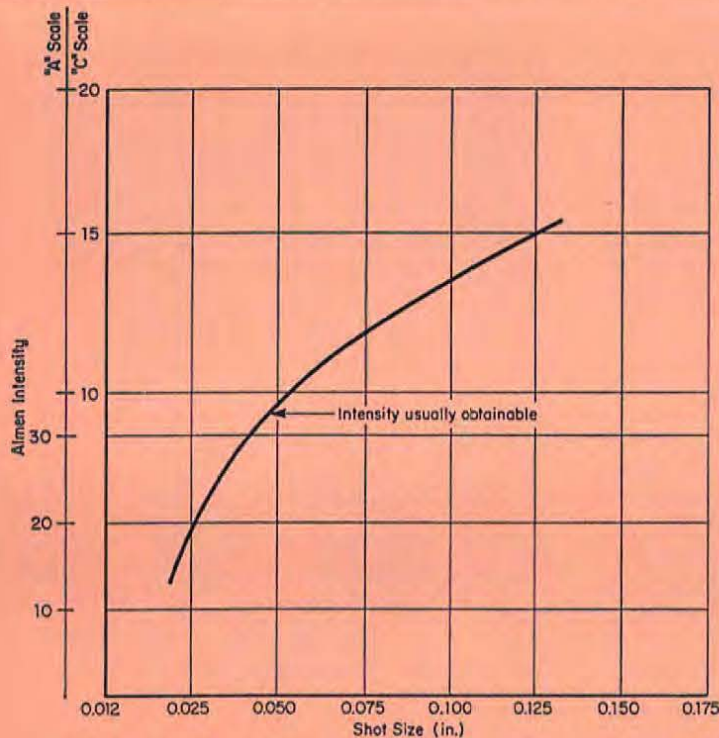
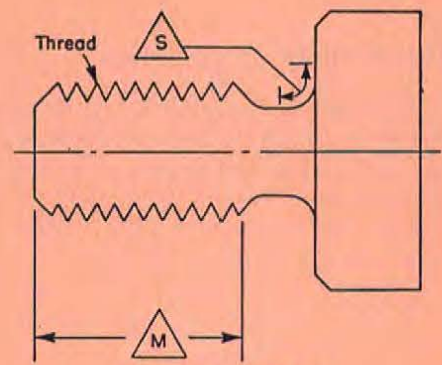

Fig. 17—Relation of shot size to peening intensity



Shot - Peening Notes

S All areas designated by this symbol must be shot peened to 0.010 - 0.014 A2 intensity per MIL-S-13165

M All areas designated by this symbol must be masked against shot impressions

Fig. 18—Drawing of typical part, with peening notes and specifications

use of shot which may not be readily available, the designer should specify a combination of Almen intensity and shot size that gives the desired result and permits use of equivalent combinations. Equivalents can be determined by tests with strips similar to Almen strips but made of the same material as the workpiece.²³

Masking: Only in a limited number of cases is peening of the entire part required, coil springs, for instance. In most engineering applications, only areas and portions subject to high tensile stresses need be treated. In other cases, highly finished areas must be protected from shot. Masking of areas which must not be peened is done either by use of special tapes or by applying a protective film. In either case, a considerable amount of labor is involved in application and removal of masking. Therefore, protection of areas should be specified only when absolutely essential. Usually it is sufficient if areas to be peened are fully covered. Shot hitting adjacent areas is usually harmless.

Shot Size: Larger shot can produce higher peening intensities but smaller shot produces full coverage more quickly, Fig 17. High intensities that require large shot (and consequent slow coverage) are more costly but are sometimes worthwhile on the softer materials.

Use of shot sizes larger than required to achieve the desired intensity results in a smoother surface

appearance and deeper penetration on aluminum parts. Consequently, it has become customary to prescribe a minimum shot size for aluminum parts where surface appearance is significant.

Need topeen into small-radius fillets may indicate a practical maximum limit on allowable shot size. A generally accepted rule of thumb permits use of a shot size (diameter) no larger than one-half the smallest fillet radius on the surface to be peened. Parts with small radius fillets cannot be peened to high intensities.

Within the given limits, the drawing callout should not stipulate a particular shot size. Any permissible leeway in shot sizes will permit more opportunity for setup, scheduling flexibility, and attendant economies and speeding of schedules.

Surface Finish: Average peening treatment on medium-hard steel will result in a roughness of 65 to 200 mu-in. rms. Same treatment on harder material will give a smoother finish than on softer material. Peening with softer shot leaves a smoother finish than hard shot. Shot softer than the workpiece may give all the benefits of peening without leaving the usual surface dimples. High spots of the peened surface can be lapped down if necessary.

Processing Sequence: Shot peening is a finishing treatment; its value is spoiled by almost any subsequent machining or heat treating processes. Thus, most operations should properly precede peening.

Heating into the stress-relieving range will destroy the residual surface stress—so will any hardening heat treatment. However, parts may be baked at temperatures not exceeding 500 F for steel or 250 F for aluminum alloys. The compressed surface layer is only a few thousandths of an inch thick, so any grinding or machining operations remove most of that layer. A light lapping or honing treatment after peening is permissible and is actually advantageous as far as the fatigue strength is concerned. In some cases, lapping about 0.002 in. from the surface will double the fatigue life. However, greater surface removal may completely spoil the effect of peening. Any cold-forming processes performed after peening may result in a complete reversal of residual stresses and should be avoided.

Peened surfaces present an excellent base for any organic or inorganic coating treatment not requiring heating (apart from a low-temperature bake) such as paint, phosphating, etc. Peened surfaces are highly receptive to oils for rust prevention and lubrication.

Peening Specifications on Drawings: Drawing callouts must include intensity and area to be peened. Reference to shot size and material may be included and, if essential, a note on areas which must be masked. As in all engineering processes, excessively small tolerances in any of these specifications multiply costs and should be avoided. The question is not, "How accurate can the part be" but "How much deviation from the standard will cause damage?" Both speed and size of peening shot are accurate only within commercial tolerances; more stringent demands cost extra money. Intensity tolerances of ± 0.002 A are good commercial practice.

Testing: In addition to the peening specifications, a drawing may also specify test procedures. Here, too, excessive requirements should be avoided, with the additional proviso that overtesting may hide the effects of peening. For instance, a part in service has a maximum deflection of $\frac{1}{2}$ in. Testing that part to a deflection of 1 in. may completely hide shot-peening effects that are very beneficial to the part under service conditions. This hiding happens because overtesting forces the part to yield and thus dissipates beneficial residual stresses.

An example of a peening specification on a drawing is shown in Fig. 18. The threaded portion of the part must obviously not be peened at all, while the turned portion can stand stray shot because such marks are not harmful to fatigue life.

REFERENCES

1. *The Matspring*, Associated Spring Corp., Bristol, Conn., February, 1951.
2. R. L. Mattson and W. S. Coleman Jr.—"Effect of Shot Peening Variables and Residual Stresses on the Fatigue Life of Leaf Spring Specimens," *Trans. Soc. Autom. Engrs.*, Vol. 62, 1954, pp. 546-556.
3. C. W. Oicles and F. K. Landecker—"Multiply Spring Life Without Changing Design," *Iron Age*, December 21, 1950.
4. E. H. Spaulding—"Lightweight Springs for Limited Life," *Proc. Soc. Autom. Engrs.*, meeting in Los Angeles, 1955.
5. O. J. Horger and C. Lipson—"Automotive Rear Axles and Means of Improving Their Fatigue Resistance," *ASTM Tech. Publ.* No. 72, June, 1946.
6. O. J. Horger—"Mechanical and Metallurgical Advantages of Shot Peening," *Iron Age*, March 29 and April 5, 1945.

7. J. M. Lessels and R. F. Brodrick—"Shot Peening as Protection of Surface Damaged Propeller Blade Material," *Internat. Conf. Fatigue of Metals*, Inst. Mech. Engrs., London, 1956.
8. P. M. Mozley—"High Strength Steel, Present Limitations," *Metal Progress*, Vol. 68, No. 1, July 1955, pp. 78-80.
9. R. L. Mattson and J. O. Almen—"Effect of Shot Blasting on Physical Properties of Steel, Part I (OSRD No. 3274), Part II (OSRD No. 4825), Part III (OSRD No. 6697), Washington, 1945.
10. N. Grossman—"Effect of Shot Peening on the Brittle Transition Temperature," *Metal Progress*, September, 1950, pp. 352-354.
11. L. P. Tarasov and H. J. Grover—"Effect of Grinding and Other Finishing Processes on the Fatigue Strength of Hardened Steel," *Proc. ASTM*, Vol. 50, 1950, p. 668.
12. J. O. Almen—"Fatigue Loss and Gain by Electroplating," *Product Engineering*, Vol. 22, No. 6, Pages 109-116.
13. H. C. O'Connor and J. L. M. Morrison—"Effect of Mean Stress on Push-Pull Fatigue Properties of Alloy Steels," *Intern. Conf. Fatigue of Metals*, Inst. Mech. Engrs., London, 1956.
14. G. Sines—"Behaviour of Metals Under Complex Static and Alternating Stresses," University of California lecture, December 8, 1953.
15. F. H. Vitovec—"The Effect of Specimen Surface as a Discontinuity in Fatigue Phenomena," Wright Air Development Center Report No. 53-167.
16. H. O. Fuchs and R. L. Mattson—"Measurement of Residual Stresses in Torsion Bar Springs," *Proc. SESA*, Vol. 4, No. 1, 1946, pp. 64-71.
17. M. Kawamoto and K. Nishioka—"Safe Stress Range for Deformation Due to Fatigue," *Trans. ASME*, Vol. 77, No. 5, July, 1955, pp. 631-634.
18. F. P. Zimmerli—"Heat Treating, Setting, and Shot Peening of Mechanical Springs," *Metal Progress*, Vol. 67, No. 6, June, 1952, pp. 97-106.
19. J. L. Waisman and A. Phillips—"Simplified Measurement of Residual Stresses," *Proc. SESA*, Vol. 11, No. 2.
20. *SAE Manual on Shot Peening*, Soc. of Autom. Engrs., New York, 1952.
21. *Military Specification on Shot Peening*, MIL-S-13165A, 1956.
22. H. J. Noble—"Shot Peening Applications in the Aircraft Industry," SAE Iron and Steel Technical Committee, Division XX, October, 1953.
23. H. O. Fuchs—"Shot Peening Effects and Specifications," Paper No. 34, Second Pacific Area Meeting, ASTM, Los Angeles, 1956.

Tips and Techniques

Planimeter Aid

When tracking an odd shape with a planimeter, the stylus often slips off the line. If a sheet of carbon paper is placed coated-side up beneath the

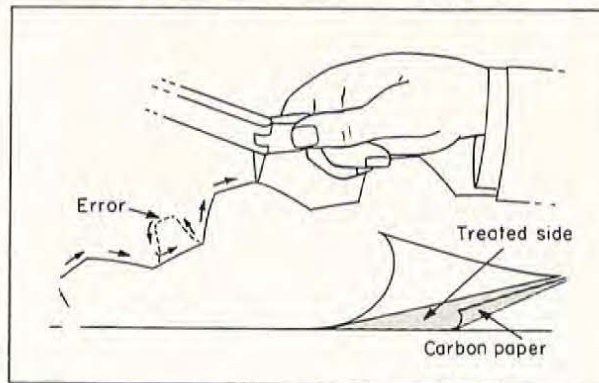

tracing paper, the pressure of the stylus will trace its own path. The area of any error may be subtracted simply by counterclockwise tracking the stylus path of the error as marked by the carbon line.—WILLIAM G. FLANNELLY, *stress engineer*, Kaman Aircraft Corp., Bloomfield, Conn.

Do you have a helpful tip or technique for our other readers? You'll receive ten dollars or more for each published contribution. Send a short description plus drawings, tables, or photos to: Tips and Techniques Editor, MACHINE DESIGN, Penton Bldg., Cleveland 13, O.