

SHOT-PEENING

A. Niku-Lari

CETIM, France

ABSTRACT

Controlled shot-peening is an operation which is used largely in the manufacture of mechanical parts. It should not be confused with sand blasting used in cleaning or descaling parts. Shot-peening is in fact a true machining operation which helps increase fatigue and stress corrosion resistance by creating beneficial residual surface stresses.

The technique consists of propelling at high speed small beads of steel cast iron, glass or cut wire against the part to be treated. The size of the beads can vary from 0.1 to 1.3 or even 2 mm. The shot is blasted under conditions which must be totally controlled.

The main advantage of this particular surface treatment is that it increases considerably the fatigue life of mechanical parts subjected to dynamic stresses. It has many uses in industry, particularly in the manufacture of parts as different as helical springs, rockers, welded joints, aircraft parts, transmission shafts, torsion bars, etc.

At a time when the optimum characteristics are being demanded of mechanical assemblies, shot-peening is a surface treatment method which is being increasingly chosen by engineers. However, shot-peening technology is not yet fully perfected and the substantial changes produced in the treated material make it difficult at the present time to put the best conditions into practical use.

KEYWORDS

Shot-peening, Residual stress, Surface roughness, Stress relaxation, Shot-size, Shot-velocity, Shot-hardness, Intensity, Fatigue.

RESUMÉ

Le grenailage de précontrainte ou shot-peening est une opération de plus en plus utilisée lors de la fabrication des pièces mécaniques. Il ne faut pas le confondre avec les nombreux usages du grenailage pour le nettoyage ou le décalaminage des pièces. Le shot-peening est en fait une véritable opération de traitement superficiel qui permet d'augmenter la tenue à la fatigue et à la corrosion sous tension en créant des contraintes résiduelles de surface.

Cette technique consiste à projeter à grande vitesse des petites billes d'acier, de fonte ou de verre sur la pièce à traiter. La dimension de ces billes peut varier de 0,1 à 1,3 mm et même de 2 mm. La projection de la grenaille est effectuée dans des conditions qui doivent être parfaitement contrôlées.

L'avantage principal de ce traitement de surface particulier est d'améliorer considérablement la durée de vie des pièces mécaniques soumises à des sollicitations dynamiques. Ses applications sont très nombreuses dans l'industrie, en particulier lors de la fabrication de pièces aussi diverses que des ressorts hélicoïdaux, poussoirs de culbuteurs, joints soudés, éléments d'avion, arbres de transmission, barres de torsion...

Dans une période où l'on exige pour les ensembles mécaniques des caractéristiques optimales, le traitement de grenailage se révèle être un outil de choix pour l'ingénieur. Mais la technologie du grenailage reste encore imparfaite, et les subtils phénomènes mis en jeu dans des matériaux traités rendent parfois difficile son utilisation pratique dans les meilleures conditions.

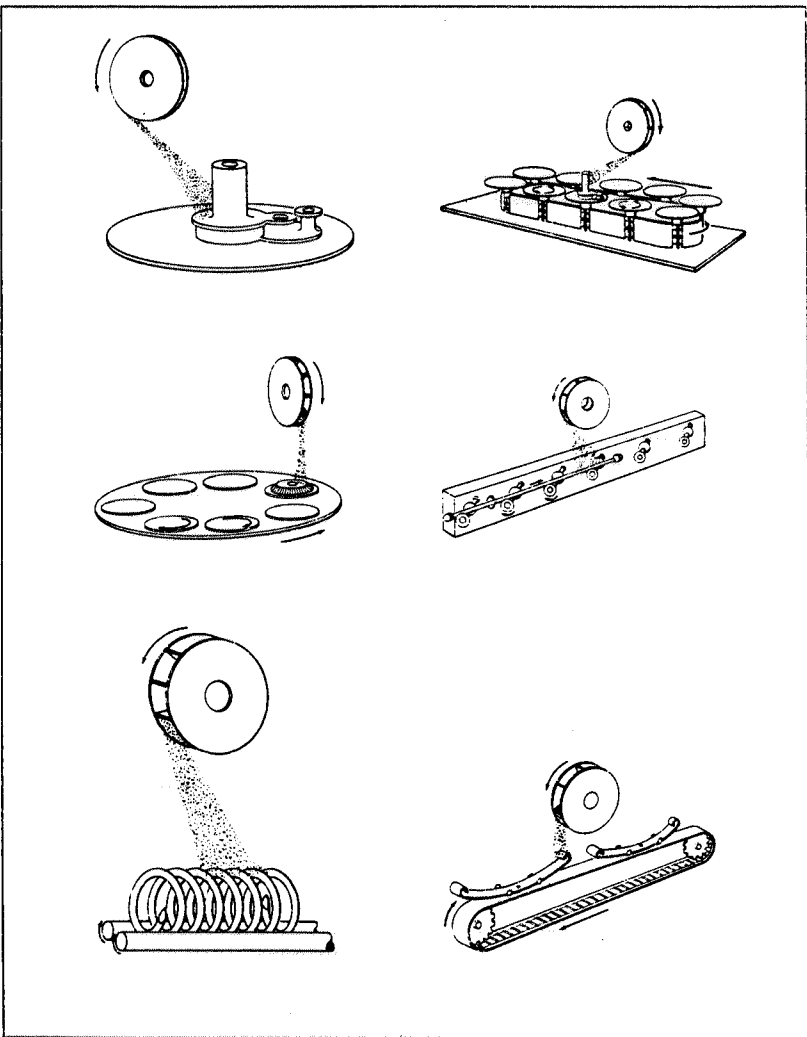

Schematic representation of some conveyor systems

THE TECHNOLOGY OF SHOT-PEENING

SHOT-PEENING MACHINES

There are numerous types of shot-peening machines. They can be divided into two categories, dependent on the method used for projecting the shot, compressed air or wheel. The choice between these two types of machine will depend on the quality of the shot-peening required and the type of part which is to be treated. Shot-peening machines can also vary considerably in the way the part is positioned in the stream of shot. There are thus drum-type machines for shot-peening parts in bulk, rotating table machines for small parts in series, linear conveyors for helical springs, and overhead conveyors (see schematic representation). Computer-controlled machines now exist with which different surfaces of the part may be treated with varying intensities. Finally, for certain cases, the shot-peening of welded joints on off-shore pipelines for example, there are portable units. Under these conditions, the shot-peening has to be manual, with a special system for recycling the shot. Like the choice of the machine, particular importance lies in the choice of the shot, which, literally, represents the tools used for this type of surface treatment.

When it is required to choose a quality of shot for a surface-hardening operation, several factors must be taken into account (1).

- The shot-peening installation and the shot used must produce the required intensity within a reasonable time.
- The surface roughness which results must be within the required tolerances.
- The depth of plastic deformed layer in the metal and the maximum residual stress must be such that the fatigue resistance is improved to the required extent.
- The life of the shot must be adequate from a financial point of view.
- The shape of the shot must remain as close as possible to the spherical, to avoid the formation of surface micro-cracks in the part, where stress concentrations would be generated in service.

Different types of shot exist for use in shot-peening treatments. Among these may be mentioned:

Cast steel shot with a hardness of 40-55 HRC, the type most frequently used for strain hardening operations by shot-peening.

Glass beads, used for delicate strain hardening operations such as on parts with slim shapes, the strain hardening of light alloys used in aircraft manufacturing, and the protection of stainless steels against stress corrosion cracking.

All Almen intensities in this work are obtained on a A-strip.

The values of the Almen intensities are given either in mm or in 1/100 of a mm. Examples:

- Almen intensity = 0.3 mm.
- 30A2 means Almen intensity = 0.3 mm.

In order to convert these values to the SAE standard one should multiply them by 40.

Almen intensity	0.1 mm	=	10A2	→	4A
"	0.2 mm	=	20A2	→	8A
"	0.3 mm	=	30A2	→	12A

Cut wire, used in a previously rounded condition, mainly in Germany, Japan and China, owing to the stability shown by its mechanical characteristics during the shot-peening operation. This type of shot is relatively little-used in France and the U.S.A.

Cast-iron shot, little-used for strain hardening operations owing to its fragility and tendency to shatter.

Refractory electro-cast balls - a new shot-peening agent, developed in France, which can be used under the same conditions as those for glass beads, while retaining its characteristics for a longer period. Various standards exist which define the quality and grain sizes for these different types of shot (3).

CONTROL OF THE OPERATION AND FUTURE DEVELOPMENT

Very many parameters are involved in shot-peening. Among them are:

- the shot speed
- the dimensions, shape, nature and hardness of the shot,
- the projection angle,
- the exposure time to the shot-peening,
- coverage.

This multiplicity of parameters makes the precise control and repeatability of a shot-peening operation very problematical. Control of shot-peening operations for strain hardening is currently achieved by means of the Almen gauge system (see footnote). For this, a steel test piece, precisely defined and standardised by American Military Standards (2), is subjected to shot-peening. When it has been released from its support, the Almen test piece has incurred a deflection, which is the result of the residual stresses which have been induced by shot-peening. These deflections are measured by means of a standardised device. For a given shot-peening condition, the variation in the deflection with the shot-peening duration may be plotted. Curves of the kind shown in Fig. 1a called saturation curves, are thus obtained. The values of the deflections obtained after a saturation time are considered to be the characteristics of the intensity of the shot-peening. Figure 1a shows the saturation curves obtained from shot-peening carried out using a wheel machine. The tests performed at CETIM on Almen gauges have shown that, for identical Almen deflection measurements, the depths of the plastic deformed layer can be very different (Fig. 1b). For the same Almen intensity, it is thus possible to cause in the material very different distributions of residual stresses. To achieve effective control of the shot-peening operation, therefore, it is necessary to examine the influence of each parameter on the generation of the residual stresses.

The inadequacy of the Almen system is becoming more and more evident to users of this technique. The difficulties in controlling the parameters of the strain hardening operation by shot-peening very often lead its users to treat it only as an extra safety factor, without taking the residual stresses due to the shot-peening into account when calculating the required dimensions of the part. Such is the practice in the American and French aircraft industries, for example. Others, such as the British, Germans, Japanese and Chinese, take the residual stresses due to shot-peening, in the stabilised condition, into account in their calculations of the fatigue resistance of the parts, in order to achieve some weight-saving (motor cars, for example).

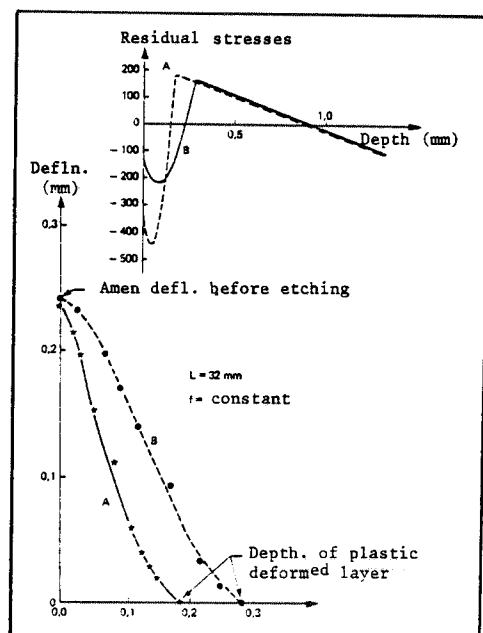
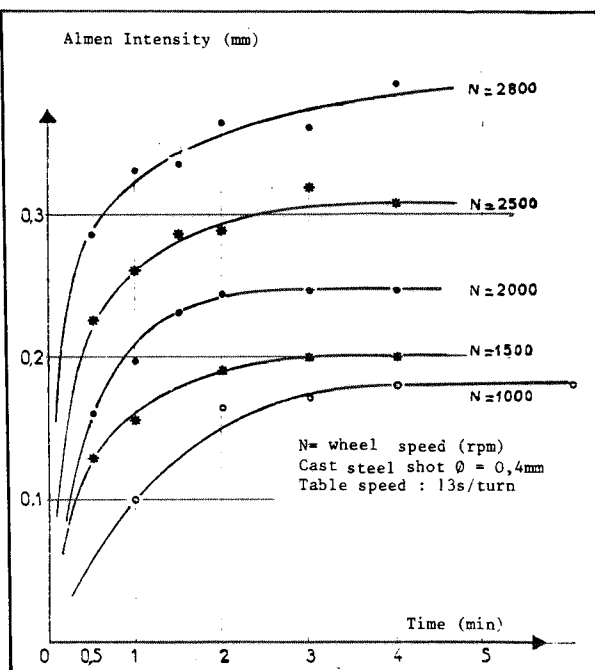

Fig. 1a. Saturation curves (S 170 shot).

Fig. 1b. Curves of deflection and residual stress obtained on two Almen test pieces with the same initial deflection.

For some years now, industry and the research establishments in the majority of industrialised countries have made considerable efforts to remove this drawback, by improving the system for the control of this operation. Several examples may be quoted of the special controls which we have encountered in various countries.

In Germany. Experimental control of the coverage on springs. Experimental curves have been plotted for each type of machine, giving the percentage of the surface area of the springs shot-peened, as a function of the spring dimensions.

In Great Britain. Development of an automatic process for determining the coverage by measuring the total energy in the shot which has been projected against the part. The developed surface area of each part requires a certain energy value for a 100, 150 or 200% coverage to be attained, and the shot-peening machine is stopped automatically when this energy is reached.

In the U.S.A. Monitoring of the surface of the part by means of a process called Peen-Scan, by which areas of the part where the treatment is insufficient or non-existent may easily be detected. This process is useful for parts with complex shapes (shot-peening of the bottoms of gear teeth, for example).

In Japan. Regular use of the X-ray method, by means of portable machines, to determine the residual stresses due to shot-peening.

In France. Development by CETIM of a theoretical and experimental method for the measurement of residual stresses, with the object of improving the system for

controlling the shot-peening operation. These tests resulted in the plotting of theoretical nomograms for high-tensile steels, which give the value of the maximum residual compressive stress in a part of any given thickness, without measurements which necessitate the destruction of the part (5).

In the future, the outcome of such investigations must result, on an industrial basis, in the better resolution of the principal restraint on the use of this technique, i.e. the difficulty in correlating the technological conditions of shot-peening and the mechanical and metallurgical state of the surface (residual stresses, metallurgical structure, roughness, etc.).

EFFECTS OF SHOT-PEENING ON THE STATE OF THE MATERIALS BEING TREATED

The requirement is to determine the effects of the technological parameters listed below on the main factors which influence the behaviour of a given material, in particular:

- metallurgical effects: structure, hardness,
- mechanical effects : residual stresses, residual stress gradient, depth of plastic deformation,
- geometrical effects : roughness.

All these factors are modified by shot-peening. We shall therefore examine systematically the influence of technological parameters, such as the velocity and size of the shot, shot hardness and the nature of the peened part.

It is worth remembering that it is very difficult to attempt to modify one of the parameters, without having some effect on the others. A change to one of the factors listed above brings about, to a greater or lesser degree, some alteration to the other test data. We have, however, done as much as possible in these tests to ensure that each parameter can be examined separately.

The examination of all these parameters, which is liable to exceed the scope of this article, will be the subject of a Guide to Shot-Peening, which is currently in the course of production at CETIM.

We give here several extracts from this document.

DEPTH OF PLASTIC DEFORMATION

Shot-peening of the material causes plastic deformation at its surface which creates residual compressive stresses. On the micrography in Fig. 3 can be seen plastic deformation of the metal, which sometimes even results in the spreading of the metal beyond the edges of the part.

The strain hardened depth is a parameter of prime importance to the fatigue resistance of material which has been shot-peened. It determines the level of the maximum residual stress, the slope of the residual stress curve, and the stability of the residual stresses under dynamic loadings. The depth of plastic deformed layer is particularly influenced by the following parameters:

- nature of the material shot-peened
- projection velocity (Almen intensity)
- shot size
- hardness of the material.

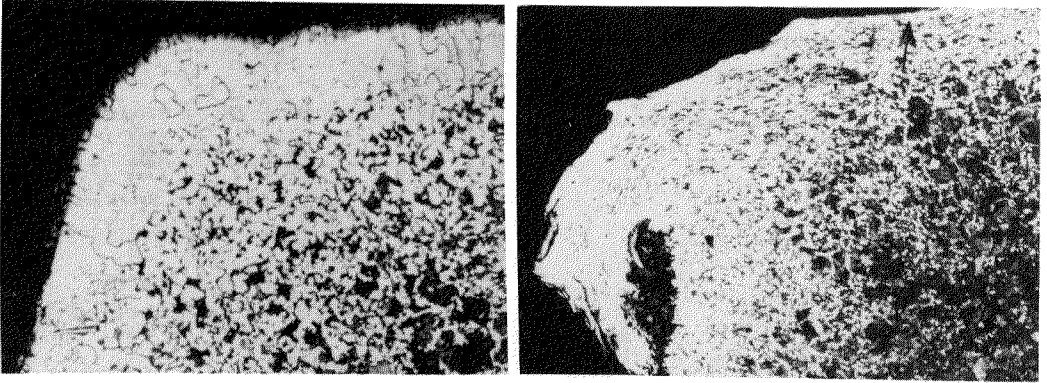

Fig. 2. Micrography of a XC 70 steel, before and after shot-peening (x 100).

The effect of the hardness of the material and the nature of the shot on the depth of metal plasticised

The overall energy absorbed by the material during shot-peening and, as a consequence, the depth of metal plasticised, depends largely on the hardness of the material from which the component is made. Furthermore, the hardness of the material determines the stability of the residual stresses, when the part is operating under dynamic loading. Figure 3 shows the variation in the depth of the metal plasticised as a function of the hardness of the material at various projection velocities (represented by the wheel speed of a wheel shot-peening machine).

It can be noted that, for all types of shot tested, the depth of metal plasticised will be reduced with an increase in the hardness of the material treated (the material shown here is grade 45 SCD 6 steel).

In addition to this, it can be seen that the differences in the depth of the work hardened strata obtained, at various velocities, will be reduced with an increase in the hardness of the shot used.

Finally, the figure shows us that the nature of the shot used influences, to a marked extent, the depth of metal plasticised. In these examples, for a given shot speed, shot type S 230 M0 produces the greatest work hardened depth, no matter what the hardness of the material from which the part is made. These results emphasise the importance that the choice of shot used for a shot-peening operation has.

The effect of the shot size on the work hardened depth

The diameter of the shot also affects the depth of metal plasticised. This parameter is cubed in the shot-peening intensity calculations and this explains the exponential nature of the curves shown in Fig. 4.

This figure shows that the depth of metal plasticised, increases for all hardnesses of material, as a function of the ball diameter and that this effect stabilises at a certain diameter.

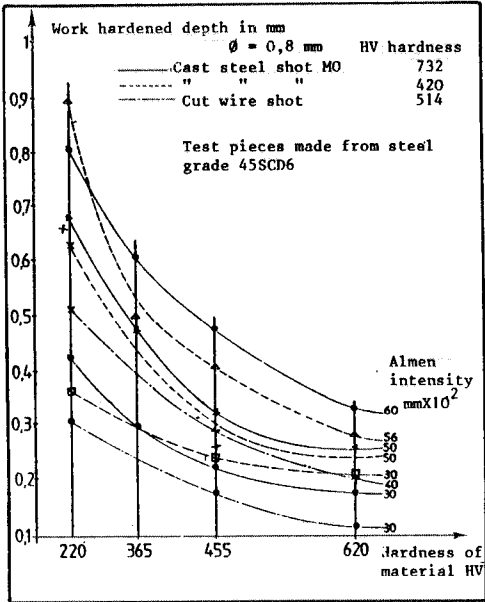

Fig. 3. Variation in the work hardened depth as a function of the material hardness, for shot of the same diameter but of different characteristics.

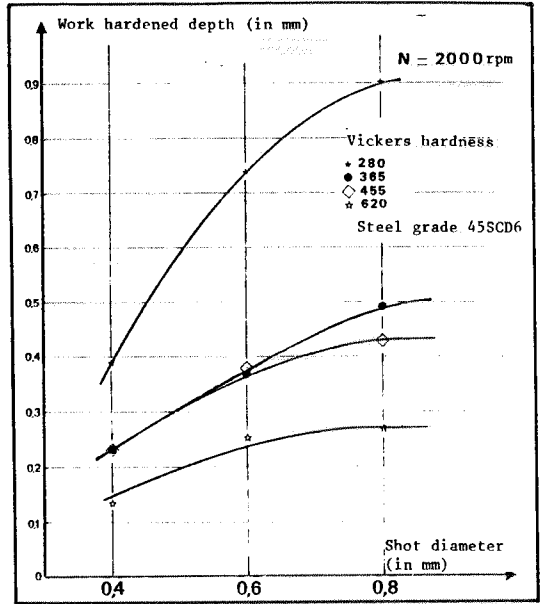

Fig. 4. The effect of the shot diameter on the depth of the work hardened strata.

Furthermore, it can be seen that the work hardened depth increases more rapidly with a progressive reduction in the hardness of the material.

The effect of the Almen intensity on the depth of the plasticity deformed layer

The shot-peening intensity, known as the Almen intensity, is a factor that depends, largely, on the projection velocity and on the shot size. Figure 5 shows the respective effects of these two parameters on the Almen intensity. This phenomenon has a direct influence on the depth of metal affected by the process.

Finally, Fig. 6 shows, for all the results obtained, the effect of the peening intensity on the work hardened depth. This diagram is very interesting in that it allows us, as a function of the material hardness, to plot theoretical diagrams for the determination of the work hardened depth without having to destroy the part.

SURFACE FINISH

The surface finish is a parameter that has a considerable effect on the fatigue strength of a part. All the shot-peening parameters modify the surface finish of the machine element. Depending on the improvement in the fatigue strength required and the surface finish tolerances that have to be adhered to, one or other of the parameters, of the operation, will have to be varied. Sometimes a double shot-peening operation is required. In this case there will first be a heavy shot-peening operation that produces a considerable plasticised depth followed by a micro-ball shot-peening operation to improve the surface finish. Sometimes the

surface is also subjected to chemical or electrochemical polishing, after shot-peening, to improve the surface finish. The figures on the following pages show the effect of a few of the shot-peening parameters on the surface finish Ra.

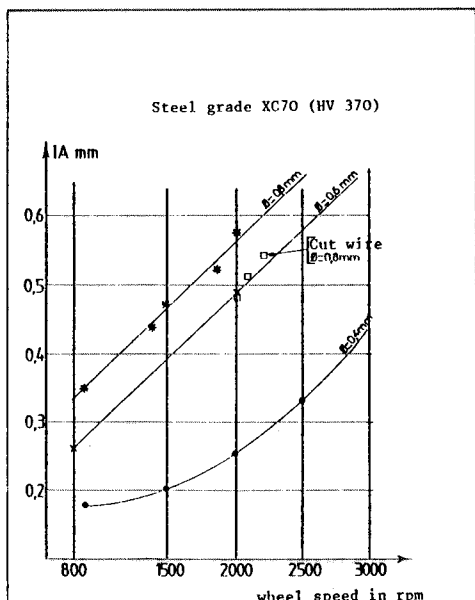

Fig. 5. Variation in the Almen intensity as a function of the blower wheel speed, for various types of shot.

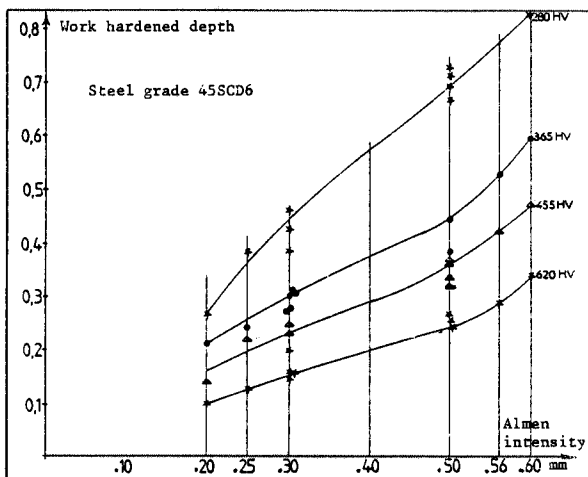

Fig. 6. Variation in the depth of metal plasticised as a function of the Almen intensity and the material hardness.

The projection velocity and the Almen intensity determine the size of the impressions caused by the shot on the surface of the material, which result in an increase in the values of Ra and Rt.

Figure 7 shows the effect of the projection velocity and the Almen intensity on the two surface finish criteria described above, for shot-peening carried out using cast steel S 330 MO shot (0.8 mm in diameter).

The shot size is a factor of vital importance to the finish obtained. It determines, on one hand the impact energy (and therefore affects the depth of the impression made) and on the other hand the diameter of the impression, which is proportional to the diameter of the shot used.

Figure 8 shows the shot size effect on the surface finish Ra, for a peening operation carried out at an Almen intensity of 30 A2.

The diagram shows that, unlike the projection velocity, an increase in the shot diameter does not necessarily increase the Ra values.

For any given material hardness, there is an optimum ball diameter that represents the best surface finish obtainable.

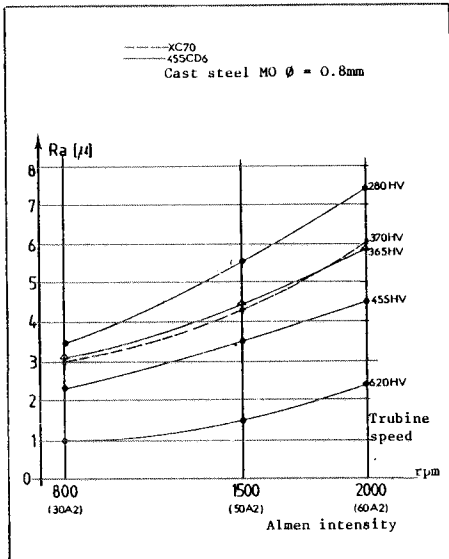

Fig. 7. The effect of the projection velocity and the Almen intensity on the surface finish Ra (S 330 MO shot - ϕ 0.8 mm).

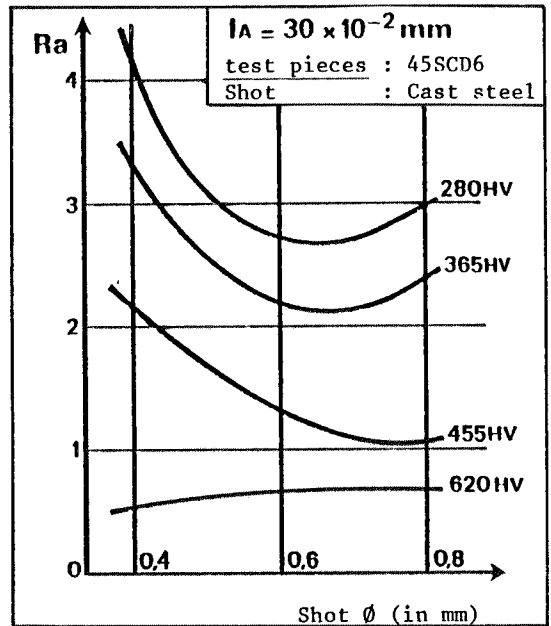

Fig. 8. The effect of the shot size on the surface finish Ra for an Almen intensity of 30 A2.

In the example stated above, 0.6 mm diameter shot provides the best results on steels of HV hardnesses from 280 to 365. In the case of steels with an HV hardness of 455, 0.8 mm diameter shot provides the best results and in the case of steel with an HV hardness of 620, it is 0.4 mm diameter shot that produces the best finish on the test piece.

We have also examined the effect of the surface hardness of the part on the surface finish values Ra and Rt, for different types of shot. Generally speaking it can be seen that:

- (i) The finish Ra and Rt decreases with the hardness of the material.
- (ii) The surface finish variation curve slope becomes steeper with an increase in the projection velocity.
- (iii) That it is cut wire shot that produces the poorest surface finish. As a result, it is essential that this type of shot should be conditioned before being used for the shot peening operations.

RESIDUAL STRESS DISTRIBUTION

The residual compression stresses introduced by shot-peening are the parameters that influence the improvement in the operating performance of the part, to the greatest extent. It is obvious that, depending on the treatment conditions, the nature of the steel and the shot used, the distribution of the residual stresses introduced will vary. We have already seen that the depth of metal plasticised will increase with the projection velocity and the shot size. This phenomenon conditions the residual stress distribution and the stability of the stresses within the material, when the part is operating.

The maximum residual stress level and the residual stress gradient will depend not only on the material from which the part is made but also the depth of metal affected.

Figures 9a to 9d show the effect of the projection velocity and the Almen intensity on the distribution of the residual stresses introduced into a grade 45 SCD 6 steel treated to a Vickers hardness of 280, 365, 455 and 620 HV respectively (peening time: 4 minutes; M0 cast steel shot diameter 0.8 mm).

Although the wheel speed and the Almen intensity have a marked effect on the distribution of residual stresses, they do not seem to affect, to any clear and extensive degree, the maximum residual stress level.

For identical peening conditions the results obtained with S 330 M0 shot and those obtained with all the other types of shot show, generally speaking:

- (i) That very hard steel (620 HV) is not sensitive to the projection velocity. The maximum residual stress level remains identical but, however, there is an appreciable difference in the stress distribution caused mainly by the depth of metal plasticised.
- (ii) That the residual stress gradient reduces in all cases (except for the metal treated to an HV hardness of 620) in line with the projection velocity and the Almen intensity.
- (iii) That in the case of materials with a low and medium degree of hardness (280 HV and 365 HV), the maximum residual stress is slightly higher when the projection velocity is higher.

A comparison between the residual stress levels as a function of the shot hardness is shown in Fig. 10.

It can be seen that in all cases, the maximum stress increases with the hardness of the material and "stabilises", for each shot diameter, at a certain level.

We think that for a given material the residual stress level at which the curve flattens out depends entirely on the hardness of the shot.

In the case of cast steel shot S 330 M0, which is harder, the maximum residual stress value is far from "stabilised" when used on a 620 HV hard material.

The effect of the shot size on the residual stress distribution is no different from that produced by the shot speed.

In fact, as in the case of the shot velocity, the stress gradient reduces with an increase in the diameter of the shot.

Except in cases of high intensity shot-peening (50 to 60 A2), on very hard steels, the shot size does not seem to have much effect on the maximum stress level (see Figs. 11a and 11b).

Yet again, it is of value to note, according to the fact that the depth of metal plasticised is greater when larger diameter shot is used, this parameter plays a vital part in the stability of the residual stress caused by shot-peening, during fatigue tests.

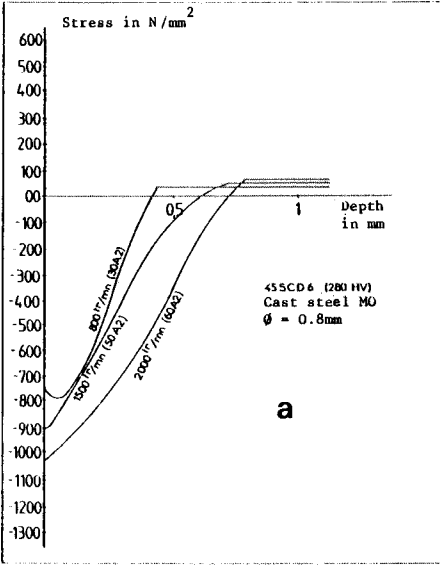

Fig. 9a. The effect of the Almen intensity and the shot velocity on the distribution of residual stresses.

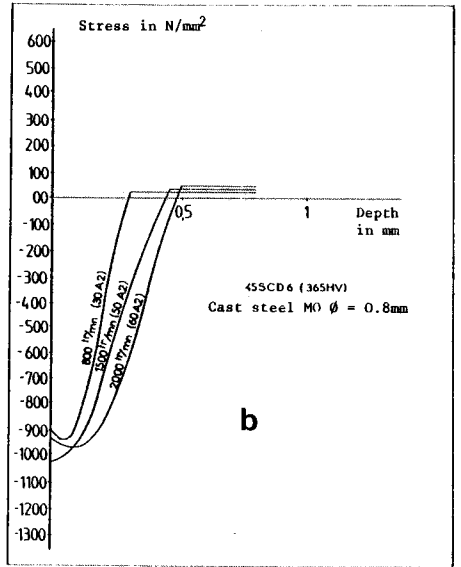

Fig. 9b. The effect of the Almen intensity and the shot velocity on the distribution of residual stresses.

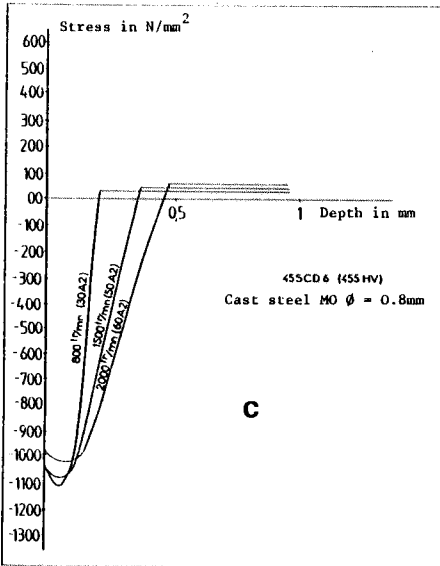

Fig. 9c. The effect of the Almen intensity and the shot velocity on the distribution of residual stresses.

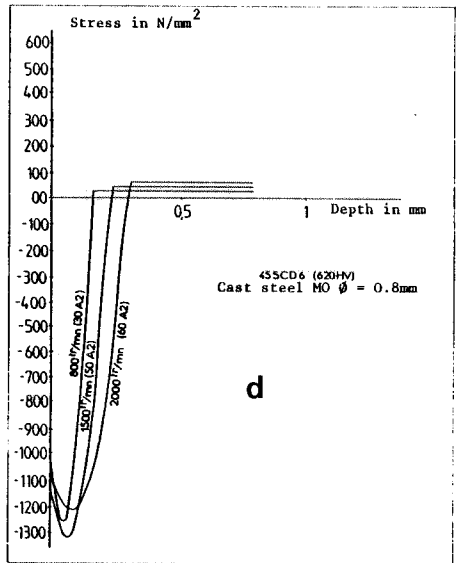

Fig. 9d. The effect of the Almen intensity and the shot velocity on the distribution of residual stresses.

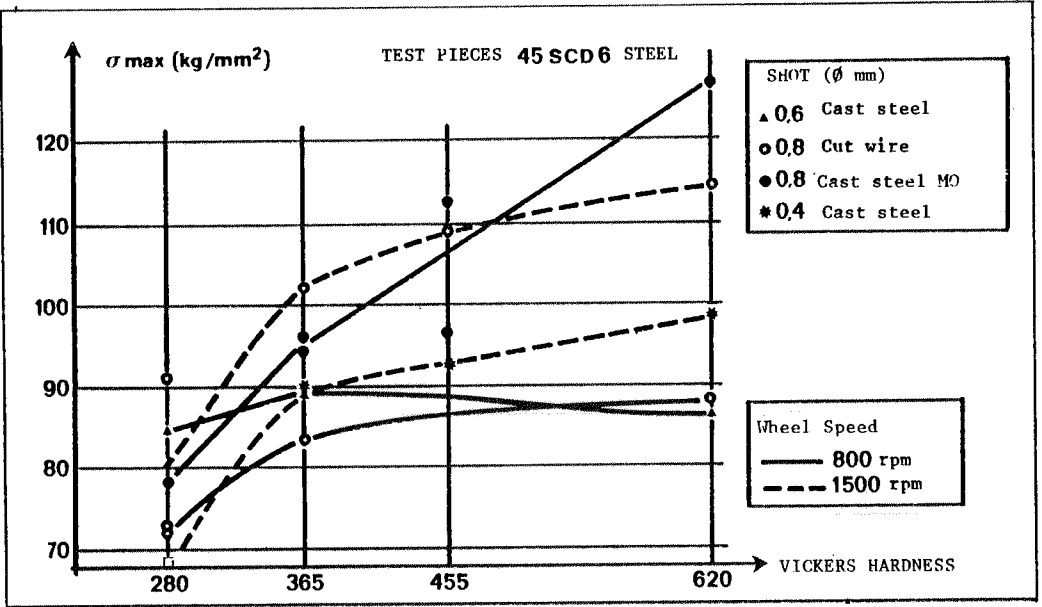

Fig. 10. Variation in the maximum residual compressive stress as a function of the hardness of the material, for various shot diameters.

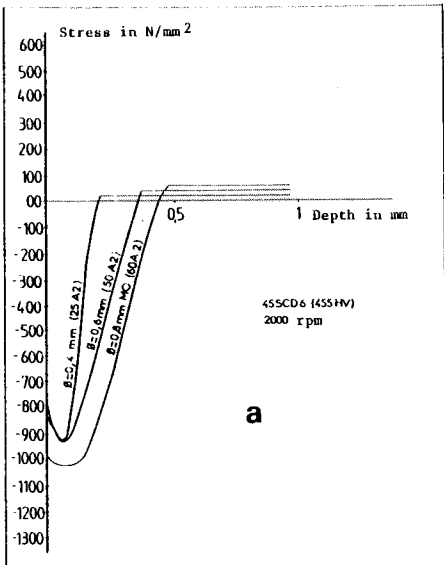

Fig. 11a. The effect of the shot diameter on the residual stress distribution.

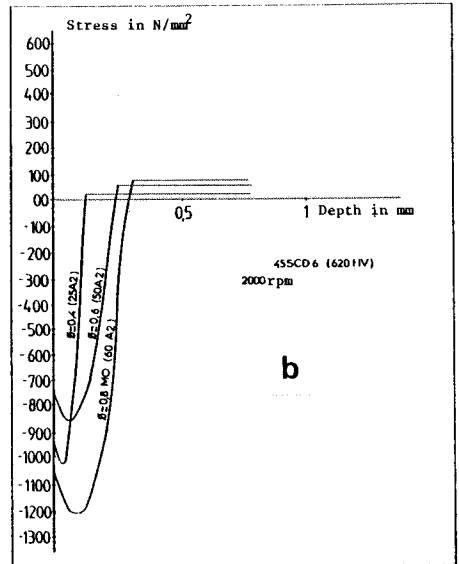

Fig. 11b. The effect of the shot diameter on the residual stress distribution.

EFFECT OF SHOT-PEENING ON THE IN-SERVICE BEHAVIOUR OF MECHANICAL PARTS

The shot-peening of mechanical parts, by altering the factors listed above, influences mainly their resistance to fatigue, corrosion fatigue and stress corrosion

Dependent on the operating conditions of the part, its resistance is influenced by one or other of the factors, as can be seen in the table below.

Factor Problem	σ_R	Ra, Rt	Depth of plastic deformed layer	Structural change	Gradient of residual stress distribution	Surface hardness
Fatigue (hard materials)	X	X	X		X	
Fatigue (materials with low hardness)			X	X		X
Corrosion fatigue	X	X	X	X		
Stress-corrosion	X	X		X		
Ultimate strength						
Pitting			X			X
Erosion		X	X			X

In the case of the effect of shot-peening on the fatigue resistance, the influence of superficial strain hardening and of residual stresses respectively may be distinguished (1) (Fig. 12).

It may thus be noted that, for materials with low characteristics, the increase in the endurance limit is, above all, due to the superficial strain-hardening and the residual stresses. On the other hand, for the high-strength materials, the fatigue resistance is mainly governed by the influence of the residual stresses.

It can thus be seen that, if the residual stresses are to be taken into account in the calculations, a serious examination must be made of the different parameters involved.

In particular, it is necessary to examine the stability of the residual stresses during cyclic loading at the operating temperature of the part.

THE RESIDUAL STRESS RELAXATION DURING FATIGUE TEST

The residual stress levels and distribution are generally altered when parts are subjected to fatigue loading. The problem is then to find out what the magnitude and distribution of the "stable" residual stresses are and to include them in our calculations.

It is essential, therefore, to appreciate the stability of residual stresses as a function of the load applied. In design calculations, for a part, one can only consider the values of the stabilised stresses, that is to say the values of those stresses that are likely to be actually present in the part during most of its operating life.

Figure 13 shows the distribution of residual stresses caused by shot-peening in a rotating bending steel test specimen that has been subjected to 1.7×10^7 operating cycles. It can be seen that the maximum residual stress level has fallen from 70 kg/mm^2 to 43 kg/mm^2 .

THE STABILITY OF RESIDUAL STRESS CAUSED BY SHOT-PEENING, DURING HEAT TREATMENT

For a certain proportion of mechanical components, manufacturers are obliged to carry out high-temperature operations on the parts. These generally cause a tempering of the material.

Other parts are working at high temperature, taking the form of tempering and stress stabilisation.

All these facts indicate the interest we should show in the stability of residual stresses during heat treatment.

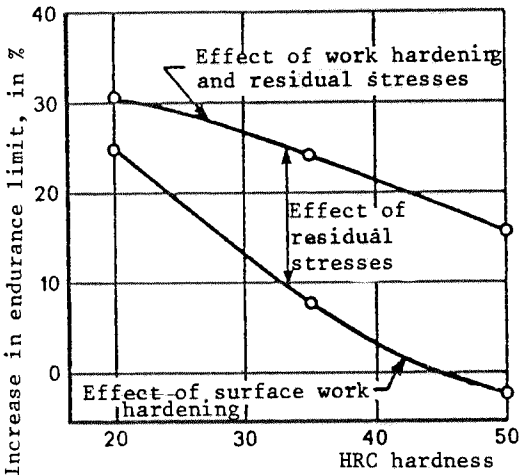

Fig. 12. The respective effects of residual stresses and work hardening on the increase in the fatigue limit of the shot-peened materials.

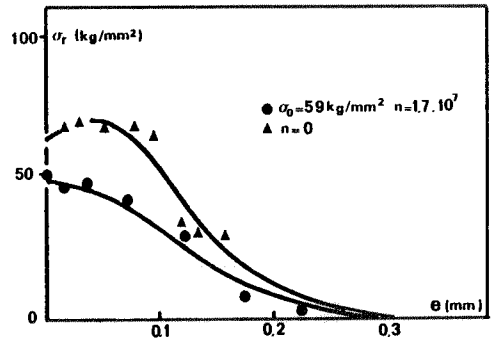

Fig. 13. The distribution of residual stresses caused by shot-peening before and after the part has been subjected to fatigue.

To examine this problem, we used Almen A type test pieces made from 45 SCD 6 steel quenched in oil (890°C) and then tempered at $425\text{--}450^{\circ}\text{C}$ to obtain a final hardness reading of 45 HRC.

The shot-peening operation on these test specimens was carried out under the following conditions:

- (i) Shot type : S 330 cast steel (diameter 0.8mm).
- (ii) Peening time: 4 min.
- (iii) Wheel speed : 1500 rpm.

The test specimens were subjected to stress relieving, at temperatures of from 100° to 600°C , after shot-peening. The test pieces were maintained at tempering temperature for half an hour.

After stress-relieving, the deflection caused by the shot-peening residual stresses in the test strips remained roughly the same as that which existed before heat treatment.

We consider this is a vital point, if one allows for the fact that a certain number of users of the shot-peening process employ the variation in the deflection, after stress-relieving, as a characteristic of the change in residual stress.

Our tests have shown that even at a tempering temperature of 600°C , after which 80% of the residual stresses are dispersed, the longitudinal deflection remains identical to that applicable before stress relieving.

Finally, Figs. 14a and 14b show the change in the deflection as a function of the depth and the corresponding residual stress distribution.

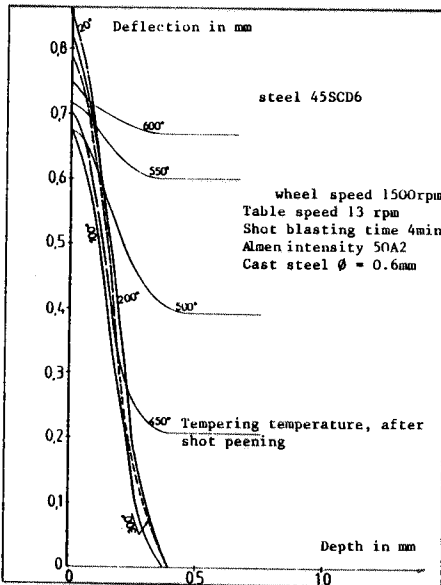

Fig. 14a. Deflection curves for test pieces that have been shot-peened and then subjected to tempering, at different temperatures.

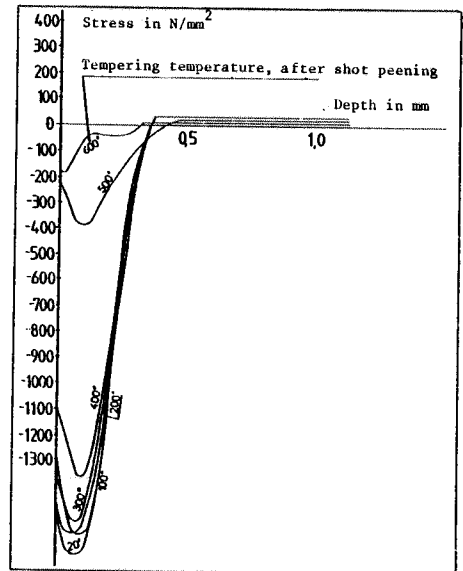

Fig. 14b. Distribution of residual stresses caused by shot-peening, after tempering, at different temperatures.

It can be seen that the stress-relieving operation has an effect on the deflection curve gradient but not on the initial deflection value. The depth of metal plasticised remains unchanged after stress relieving.

PRACTICAL CASES OF THE IMPROVEMENT IN THE FATIGUE LIFE OF PARTS BY SHOT-PEENING

Shot-peening has numerous applications; the following table (1) gives a few examples.

Type of part	Applied stress	Increase in service life (%)
Pins	Alternate bending	400-1900
Shafts	Torsion	700
Gearbox shafts	Service life tests	80
Crankshafts	" " "	3000 but very variable
Aircraft link rods	Push/pull	105
Connecting rods	" "	45
Leaf springs	Dynamic stress	100-340
Helical springs	Service life	3500
Torsion bars	Dynamic stress	140-600
Cardan coupling shafts	Alternate bending	350
Gears	Service life tests	130
Tank tracks	" " "	1100
Weldments	" " "	200
Valves	" " "	700
Rocker arms	" " "	320

We shall now describe four practical cases that are amongst the many that users of this technique have sent to us for inclusion in the "practical application pages" of the Shot-peening Guide.

Lifting hooks made from steel grade 20 NCD2 quenched and tempered

In these tests we compared the fatigue limit of the hooks in the as-peened condition with those of the as-polished and as-unpeened conditions.

The shot-peening treatment that we applied to the entire component only affects, in fact, the critical area. The part was polished only on the shaded area (see Fig. 16).

Shot-peening was carried out under the following conditions:

- shot-peening period : 10 minutes;
- saturation time : 1 minute;
- type of shot used : MI 330, diameter 0.8 mm;
- shot-peening intensity: 6 Almen C → (SAE specifications);
- coverage : 150 to 200%;
- type of machine : turbine blower.

Figure 15 shows the Wöhler curve obtained for hooks in their original condition, when polished and in the shot-peened condition. It can be seen that the 50% failure probability endurance limit stood at a load of 2400 daN for hooks in the original condition and 4250 daN for hooks that have been subjected to shot-peening.

The aim was to compare the effect of polishing and of shot-peening on the fatigue limit of the parts in question.

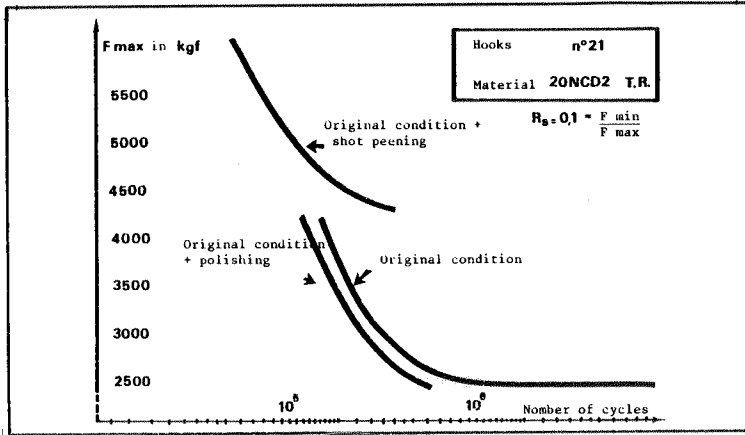

Fig. 15. Influence of shot peening on fatigue limit of lifting hooks.

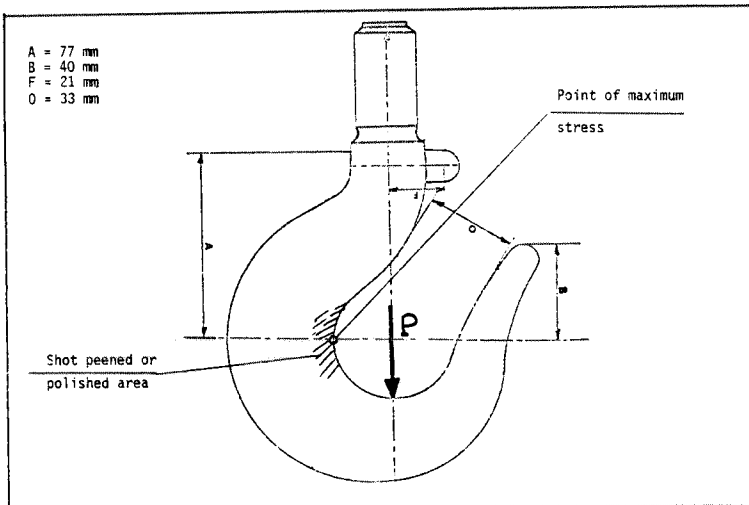
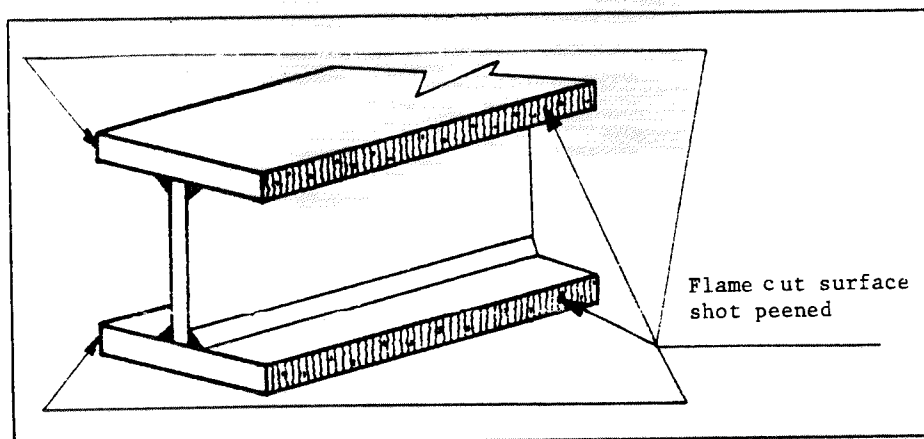

Fig. 16. Critical point on part.

Figure 16 shows a schema of the part and the critical point representing the maximum operating stress area on the hook.

It can be seen, on the one hand, that the polishing operation reduces the fatigue limit of the part, no doubt because the hooks in their original condition had already been subjected to a cleaning sand blasting operation. The polishing operation removed the residual stress caused by this cleaning and this resulted in a fall in the fatigue specification of the parts. The shot-peening operation, however, considerably increased the endurance limit of the hooks (90%).

Welded structure, flame cut plate

Source of information: CRIF - Section pont et charpentes (B).

Material: Construction Steel: AE235 - AE355.

Type of in-service loading : push-pull.

Life of part:

Surface condition	Fatigue life for $\Delta \sigma = 180 \text{ N/mm}^2$	Endurance limit for $N = 2 \times 10^6$ cycles
Without peening	0.7×10^6 cycles	$\Delta \sigma = 132 \text{ N/mm}^2$
Shot-peened	1.35×10^6 cycles	$\Delta \sigma = 165 \text{ N/mm}^2$

Shot-peening conditions:

- Shot: steel shot : 1 mm diameter.
- Peening time : 1.5 min.
- Wheel speed : 3000 rpm - wheel diameter: 500 mm.
- Distance to wheel: 1 m.
- Peened area : flame cut surface.

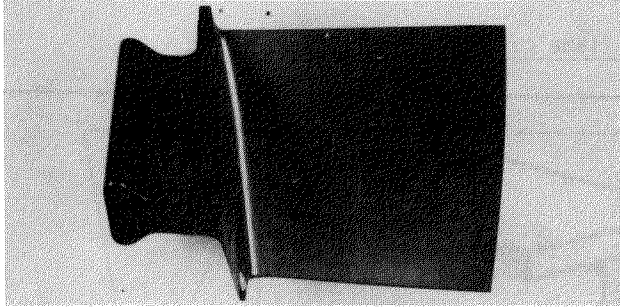
Compressor blades

Source of information: TURBOMECA - France.

Material : titanium alloy.
 Treated zone: blade body.
 Type of in-service loading: bending and torsion.
 Life of part: 100% increase in fatigue life.

Shot-peening conditions:

- Glass beads : 240-320 μm .
- Almen intensity: 30N = 0.3 mm measured on N strip.
- Coverage : 120%.
- Surface roughness after peening: $R_a = 1.1 \mu$.

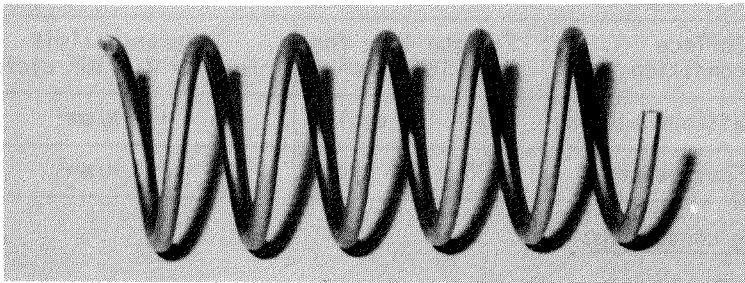
Compression springs (Automobile valve springs)

Source of information: Salter Springs and Pressing Ltd. (U.K.)

Wire size : $d = 3.85 \text{ mm}$.
 Mean diameter : $D_m = 38 \text{ mm}$.
 Space between coils: 15.8 mm.
 Number of coils: 5.75.
 Material : high tensile spring wire.
 Tensile strength: 1700 N/mm².
 Type of in-service loading: torsion.
 Life of part : typically the fatigue limit is increased by 25 to 30% due to shot-peening.

Shot-peening conditions:

- Bulk treated : 4 to 5000 springs per batch.
- Shot : cut wire, 0.8 mm diameter.
- Almen intensity: not measured.
- Coverage : 100%.
- Shot-peening equipment: wheel machine
- Residual stress after peening: 400 N/mm² residual compressive stress.

CONCLUSION

We have shown the influence of a certain number of technological parameters of shot-peening on the factors which affect the behaviour of materials. In particular, we have demonstrated the effect of the velocity, size and type of shot, together with the hardness of the material of which the part consists, on the value and the distribution of the residual stresses, the depth of the plastic deformed layer and the surface roughness.

Strain hardening by shot-peening is an operation which broadly increases the resistance of mechanical parts to fatigue and to stress corrosion. This increase is particularly due to the presence of residual compressive stresses in the surface layers of the material. The fact that the residual stresses due to shot-peening change during the service life of the part, particularly when it is operating at high temperatures, makes it difficult to take these residual stresses into account when calculating the behaviour of the material.

To overcome this problem, we believe that future research activity should be directed towards the achievement of the following results:

- better control of the shot-peening operation by improving the Almen system;
- better understanding of the effects which the technological parameters of the process have on the microstructural and mechanical characteristics of the material;
- better understanding of the residual stresses relaxations which occur during the service life of the part;
- better understanding of the fatigue criteria and their applications to the shot peened parts.

REFERENCES

- | | |
|---|---|
| <p>[1] FLAVENOT et NIKU-LARI. — Le grenailage de pré-contrainte. <i>Note technique du CETIM</i>, n° 15.</p> <p>[2] <i>SAE Manuel on shot peening</i>, SAE J 908 a 1967.</p> <p>[3] <i>Shot peening of metal parts, Military specification</i>, N° MIL - S - 13165 A.</p> <p>[4] ALMEN. — Fatigue weakness of surfaces, <i>Product Engineering</i>, Vol. 21, n° 11, nov. 1950.</p> <p>[5] FLAVENOT et NIKU-LARI. — La mesure des contraintes résiduelles, méthode de la flèche, méthode de la source de contraintes. <i>Les mémoires techniques du CETIM</i>, n° 31, sept. 1977.</p> <p>[6] STRIGENS. — Influence du durcissement superficiel sur l'endurance des aciers, <i>Thèse Darmstadt</i>, 1971.</p> <p>[7] KRAUTMACHER. — <i>Stahl und Eisen</i>, Vol. 78, 1968.</p> | <p>[8] HANLEY. — Le grenailage pour obtenir des meilleurs finis. <i>Machine design</i>, Vol. 47, n° 7, mars 1975.</p> <p>[9] HERTEL. — <i>Ermüdungs festigkeit des konstruktionen</i>. Springer Verlag Berlin, 1966.</p> <p>[10] MATTSON. — Fatigue, residual stresses and surface cold working, International conference on fatigue of metals. <i>I. Mech. E.</i>, 1957.</p> <p>[11] LEPAND. — <i>Anderung des dauerschwung</i>. Verhalten van Federstahl 50 Cr V4. <i>Dissertation Clausthal</i>, 1965.</p> <p>[12] HEMPEL. — Essais sur des ressorts hélicoïdaux. <i>Konstruktion</i>, Vol. 6, n° 2, 1954.</p> <p>[13] BLEILOB et KAISER. — Résistance à la fatigue, par oscillations, de ressorts en fil-ressort inoxydable selon DIN 17224, et propriétés des fils de ce genre. <i>Draht-Weit</i>. Vol. 57, n° 1, janvier 1971.</p> <p>[14] SOLD et Coll. — Improving bending fatigue of large module gear teeth Russian engineering journal, Vol. L 4 n° 1, 1972.</p> |
|---|---|