

Technical Report Documentation Page

1. Report No. FHWA/TX-06/5-4178-01-2		2. Government Accession No.	3. Recipient's Catalog No.	
4. Title and Subtitle Application of Ultrasonic Impact Treatment to In-Service Signal Mast Arms		5. Report Date June 2005, Rev. November 2005		
		6. Performing Organization Code		
7. Author(s) Amanda H. Palmatier, Karl H. Frank		8. Performing Organization Report No. 5-4178-01-2		
9. Performing Organization Name and Address Center for Transportation Research The University of Texas at Austin 3208 Red River, Suite 200 Austin, TX 78705-2650		10. Work Unit No. (TRAIS)		
		11. Contract or Grant No. 5-4178-01		
12. Sponsoring Agency Name and Address Texas Department of Transportation Research and Technology Implementation Office P.O. Box 5080 Austin, TX 78763-5080		13. Type of Report and Period Covered Technical Report (09/01/03 - 08/31/05)		
		14. Sponsoring Agency Code		
15. Supplementary Notes Project performed in cooperation with the Texas Department of Transportation and the Federal Highway Administration.				
16. Abstract  The application of Ultrasonic Impact Treatment (UIT) to signal mast arms in the field is described. UIT has been demonstrated in the laboratory to provide a simple means to improve the fatigue performance of the fillet weld of connection of the mast arm tube to the end plate. The procedures used in the field are detailed and the time required for a repair documented. A fatigue test of a mast arm treated in the field is presented. The fatigue test indicated that the UIT treatment improved the performance of the connection to the level of a connection with a thicker end plate. UIT provides a cost effective means of increasing the service life of the mast arms at intersections where galloping oscillations of the mast arms have been observed.				
17. Key Words UIT, Ultrasonic, Impact, Treatment, fatigue, mast arm, Ferguson, signal		18. Distribution Statement No restrictions. This document is available to the public through the National Technical Information Service, Springfield, Virginia 22161; www.ntis.gov.		
19. Security Classif. (of report) Unclassified	20. Security Classif. (of this page) Unclassified	21. No. of pages 31	22. Price	





**FERGUSON STRUCTURAL ENGINEERING LAB**  
**The University of Texas at Austin**

## **Application of Ultrasonic Impact Treatment to In-Service Signal Mast Arms**

Amanda H. Palmatier  
Karl H. Frank

---

CTR Research Report:	5-4178-01-2
Report Date:	June 2005
Research Project:	5-4178-01
Research Project Title:	Ultrasonic Impact Treatment (UIT) for Traffic Signal Structure Fatigue Details
Sponsoring Agency:	Texas Department of Transportation
Performing Agency:	Center for Transportation Research at The University of Texas at Austin

Project performed in cooperation with the Texas Department of Transportation and the Federal Highway Administration.

Center for Transportation Research  
The University of Texas at Austin  
3208 Red River  
Austin, TX 78705

[www.utexas.edu/research/ctr](http://www.utexas.edu/research/ctr)

Copyright (c) 2006  
Center for Transportation Research  
The University of Texas at Austin

All rights reserved  
Printed in the United States of America

## **Disclaimers**

**Author's Disclaimer:** The contents of this report reflect the views of the authors, who are responsible for the facts and the accuracy of the data presented herein. The contents do not necessarily reflect the official view or policies of the Federal Highway Administration or the Texas Department of Transportation (TxDOT). This report does not constitute a standard, specification, or regulation.

**Patent Disclaimer:** There was no invention or discovery conceived or first actually reduced to practice in the course of or under this contract, including any art, method, process, machine manufacture, design or composition of matter, or any new useful improvement thereof, or any variety of plant, which is or may be patentable under the patent laws of the United States of America or any foreign country.

Notice: The United States Government and the State of Texas do not endorse products or manufacturers. If trade or manufacturers' names appear herein, it is solely because they are considered essential to the object of this report.

### **Engineering Disclaimer**

NOT INTENDED FOR CONSTRUCTION, BIDDING, OR PERMIT PURPOSES.

Karl H. Frank, P.E., Texas No. 48953

*Research Supervisor*



## **Acknowledgments**

We greatly appreciate the financial support from the Texas Department of Transportation that made this project possible. The support of the project director, Heather Gilmer (BRG) is also very much appreciated. The help and technical expertise of Blake Stasney, Dennis Phillip and Mike Bell of the Ferguson Laboratory staff contributed to the success of the research.



# Table of Contents

<b>Chapter 1: Introduction .....</b>	<b>1</b>
<b>Chapter 2: Field Application of UIT to Signal Structures.....</b>	<b>3</b>
2.1 LOCATION OF MAST ARMS .....	3
2.2 ACCESS TO MAST ARMS .....	5
2.3 UIT APPLICATION PROCEDURE.....	6
2.4 INSPECTION.....	8
2.5 APPLICATION TIMES .....	9
2.6 MISCELLANEOUS OBSERVATIONS OF FIELD OPERATIONS.....	9
<b>Chapter 3: Laboratory Fatigue Test of Mast Arms .....</b>	<b>11</b>
3.1 INTRODUCTION .....	11
3.2 TEST SPECIMEN GEOMETRY.....	11
3.3 STATIC TESTS .....	14
3.4 FATIGUE TESTS .....	18
3.5 FATIGUE TEST RESULTS.....	22
3.6 FIELD UIT APPLICATION VS. FABRICATION YARD UIT APPLICATION .....	23
3.7 WELD TOE GEOMETRY .....	25
<b>Chapter 4: Summary and Conclusions.....</b>	<b>29</b>
4.1 FIELD APPLICATION OF UIT.....	29
4.2 IMPROVEMENT IN FATIGUE PERFORMANCE .....	29
4.3 CONCLUSIONS .....	29
<b>References.....</b>	<b>31</b>



## List of Figures

FIGURE 2.1 SATELLITE IMAGE OF THE INTERSECTIONS BEING TREATED WITH UIT .....	3
FIGURE 2.2 MAST ARM 1 ON THE NORTHEAST CORNER OF THE NORTH INTERSECTION OF I-35E AND BONNIE BRAE STREET IN DENTON, TX.....	4
FIGURE 2.3 MAST ARM 2 AT THE SOUTHWEST CORNER OF THE SOUTH INTERSECTION OF I-35E AND BONNIE BRAE STREET IN DENTON, TX.....	4
FIGURE 2.4 HORIZONTAL DAMPING PLATE ON MAST ARM 2 .....	5
FIGURE 2.5 FATIGUE CRACK AT END PLATE WELD TOE IN LABORATORY SPECIMEN .....	6
FIGURE 2.6 MAST ARM 2 AFTER UIT APPLICATION.....	7
FIGURE 2.7 MAST ARM 2 AFTER UIT AND APPLICATION OF ZINC RICH SPRAY PAINT .....	7
FIGURE 2.8 UIT APPLICATION AT THE BOTTOM OF MAST 2.....	8
FIGURE 3.1 DU MAST ARM ENDPLATE DIMENSIONS, 1 IN. THICK.....	12
FIGURE 3.2 DN MAST ARM ENDPLATE DIMENSIONS, 1-1/4 IN. THICK .....	12
FIGURE 3.3 BEVELED WASHERS USED BETWEEN END PLATE AND LOADING BOX .....	13
FIGURE 3.4 LOCATIONS OF STRAIN GAUGES .....	15
FIGURE 3.5 ACTUAL AND EXPECTED STRAIN AT 3 INCHES FROM THE MAST ARM WELD TOE OF SPECIMEN DU .....	16
FIGURE 3.7 STRAIN AT THE MID-HEIGHT OF BASEPLATE DU.....	17
FIGURE 3.8 STRAIN AT THE MID-HEIGHT OF BASEPLATE DN.....	17
FIGURE 3.9 CLOSE-UP OF FATIGUE CRACK ON SPECIMEN DU MAST ARM WELD TOE ALONG THE UIT APPLICATION LINE (90,680 CYCLES) .....	19
FIGURE 3.10 HIGHLIGHTED FATIGUE CRACK ON SPECIMEN DU MAST ARM WELD TOE ALONG THE UIT APPLICATION LINE (90,680 CYCLES) .....	19
FIGURE 3.11 CLOSE-UP OF FATIGUE CRACK ON SPECIMEN DU MAST ARM WELD TOE ALONG THE WELD REPAIR (116,876 CYCLES).....	20
FIGURE 3.12 STIFFENER ADDED TO MAST ARM DU AFTER 116,876 CYCLES .....	21
FIGURE 3.13 CLOSE-UP OF FATIGUE CRACK ALONG MAST ARM WELD TOE OF SPECIMEN DN (224,905 CYCLES) .....	21
FIGURE 3.14 HIGHLIGHTED FATIGUE CRACK ALONG MAST ARM WELD TOE OF SPECIMEN DN (224,905 CYCLES) .....	22
FIGURE 3.15 S-N PLOT OF DU, DN, AND AASHTO FATIGUE CATEGORIES.....	23
FIGURE 3.16 S-N PLOT FOR DU, DN, AND THE TAU SERIES.....	24
FIGURE 3.17 STANDARD MAST ARM-END PLATE WELD DIMENSIONS FROM TxDOT STANDARD MA-C-96 .....	26
FIGURE 3.18 TYPICAL WELD LEG LOCATIONS .....	27
FIGURE 3.19 10X MAGNIFICATION OF MAST ARM WELD BEFORE UIT .....	27
FIGURE 3.20 10X MAGNIFICATION OF MAST ARM DU WELD AFTER UIT .....	28



## List of Tables

TABLE 2.1 UIT APPLICATION TIMES .....	9
TABLE 3.1 SUMMARY OF CALCULATIONS FOR SPECIMENS DU AND DN .....	14
TABLE 3.2 MAXIMUM AND MINIMUM LOADS AND DEFLECTIONS DURING DYNAMIC TESTING .....	18
TABLE 3.3 TEST RESULTS FOR TA SERIES, TAU SERIES, DU, AND DN.....	24
TABLE 3.4 WELD TOE GEOMETRIES .....	28



## **Chapter 1: Introduction**

Laboratory fatigue studies of traffic signal mast arms have shown that application of Ultrasonic Impact Treatment, UIT, to the weld toes of the mast arm to end plate connection provides a simple way of improving the fatigue performance of the connection [1]. Consequently, UIT holds the promise of an efficient method of improving the fatigue performance of in-service structures. The research has shown that in order for UIT to be effective it must be applied when the weld is under dead load and after the assembly has been galvanized. Both of these conditions are met in the field applications. This report documents the procedure used on two mast arms in Denton, Texas. The procedure described in this report has also been used by TxDOT personnel on other mast arms in the state. The report is intended to document the procedure and to serve as a guide for use of UIT.



## Chapter 2: Field Application of UIT to Signal Structures

### 2.1 Location of Mast Arms

Two traffic signal structures on the corners of the frontage road of I-35E and Bonnie Brae Street in Denton, TX were retrofitted using UIT. Structure 1 is on the Northeast corner of the North intersection, and Structure 2 is on the Southwest side of the South intersection. Figure 2.1 shows a satellite photo of the two intersections where structures 1 and 2 were located.



*Figure 2.1 Satellite Image of the Intersections Being Treated with UIT*

The location of the structures for UIT retrofit was chosen due to a recent fatigue failure of the mast arm on Structure 1. Many of the treated arms were similar in geometry and subjected to similar wind conditions as the failed arm. The UIT treatment was applied to increase the fatigue resistance of these arms and prevent future service failures.

Mast arm 1, shown in Figure 2.2, is 24 feet long 7.5 inch diameter with an end plate bolt spacing of 6" x 10". Mast arm 2, shown in Figure 2.3, is 8 inch diameter 28 feet in length with an end plate bolt spacing of 7" x 11". Mast arm 2 has been in service for approximately 10 years. Mast arm 1 was replaced after a recent fatigue failure, and had been in service approximately one year at the time of treatment.



*Figure 2.2 Mast Arm 1 on the Northeast Corner of the North Intersection of I-35E and Bonnie Brae Street in Denton, TX*



*Figure 2.3 Mast Arm 2 at the Southwest Corner of the South Intersection of I-35E and Bonnie Brae Street in Denton, TX*

Mast arm 1 has two signals. The first signal, closest to the mast, has three lights. There are two signs next, and then a five light signal. Finally, at the end of the mast arm is a rectangular horizontal damping plate which is intended to prevent galloping.

Mast arm 2 has a street sign right next to the mast, followed by a one-way sign. Next is a three light signal, followed by another sign. At the end of Mast arm 2 is a five light signal. A horizontal rectangular damping plate is behind the five light signal. The damping plate on Mast arm 2 is shown in Figure 2.4.



*Figure 2.4 Horizontal Damping Plate on Mast Arm 2*

## **2.2 Access to Mast Arms**

Access to the mast arm weld was provided by a bucket truck as shown in Figures 2.2 and 2.3. Traffic was constant and heavy, but not congested at the sites. Traffic was not impacted because the bucket truck was either parked partially on the grass or out of the way of traffic. Traffic cones were used to define the work zone. A similar setup was used in the application of UIT to signal arms at other locations. In general, the mast arm welds could be accessed safely using a bucket truck with minimal disruption of traffic

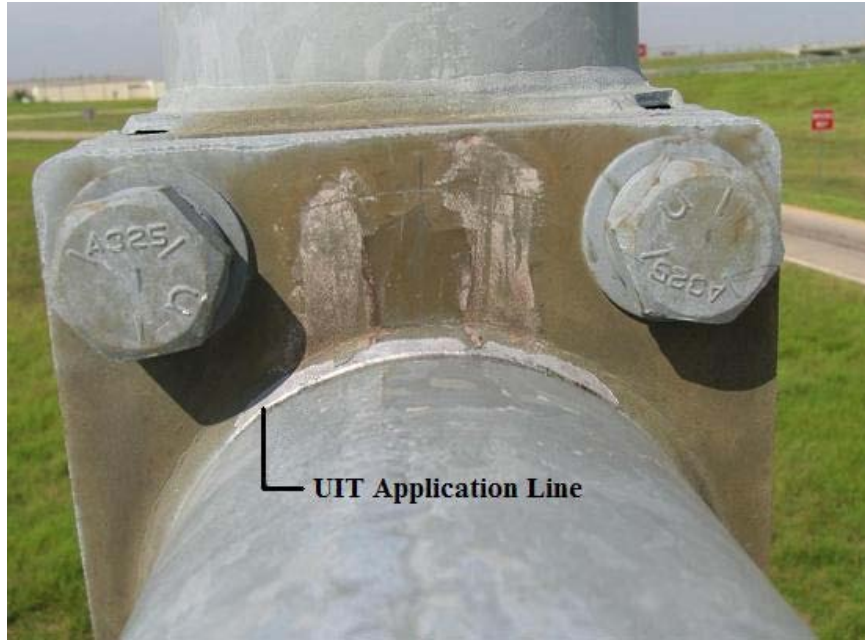
### 2.3 UIT Application Procedure

UIT was applied to both the end plate-mast arm weld and the baseplate-mast weld. UIT retrofit in Denton was part of a two-day UIT retrofit effort. Selected arms in other cities had UIT retrofit the day before the work in Denton. Based upon laboratory tests of mast arms treated with UIT, the researchers recommended that UIT should be applied to both the weld toe on the mast arm and the toe on the end plate. In previous tests, mast arms treated only at the mast arm toe developed cracks at the untreated weld toe at the plate often before cracking at the treated weld. A photo of a crack at the weld toe at the plate from previous research is shown in Figure 2.5. It was decided to apply UIT to only the mast arm weld toe for Mast arm 2, following the same treatment parameters that were used in the other cities, and apply UIT to both weld toes for Mast arm 1. A multi-pin UIT tool with 3 mm diameter pins was used at all sites.

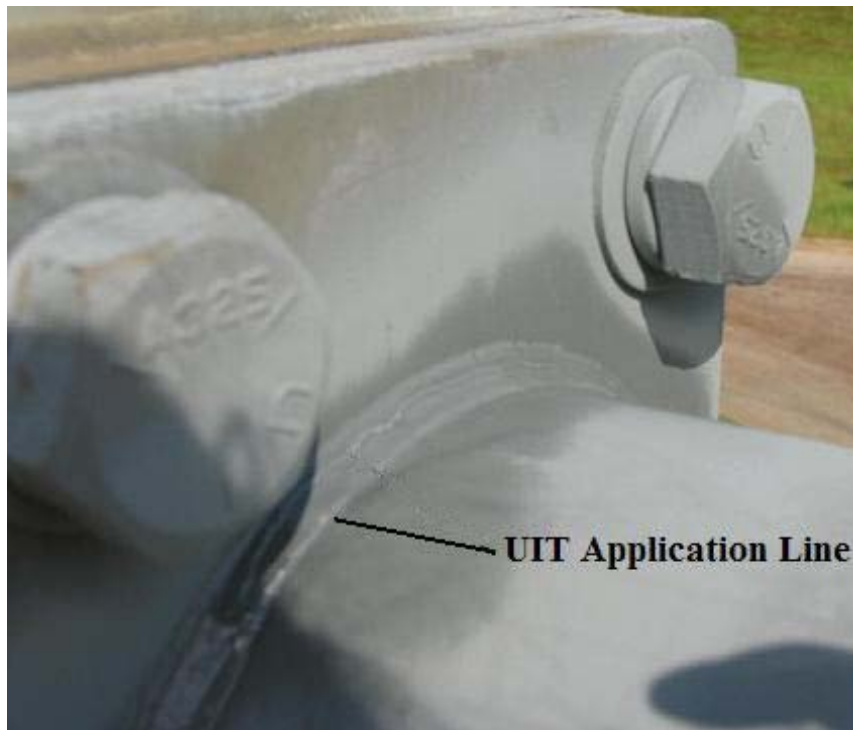


*Figure 2.5 Fatigue Crack at End Plate Weld Toe in Laboratory Specimen*

Figure 2.6 and Figure 2.7 show the weld on Mast arm 2 after treatment and after spraying with the zinc rich paint to restore the galvanic corrosion protection to the treated region. Figure 2.8 shows the weld at the base of Mast 2 after treatment. The treated region of the weld is visible as the shinier area in Figures 2.6 and 2.8. The treatment was applied only to the top tension portion of the mast arm joint. The weld of the mast to the base plate was treated all around the joint. The bolts attaching the end plate to the mast interfered with the UIT tool which prevented treatment to the weld adjacent to the bolts. The treatment should be applied to as much of the weld on the top of the mast arm as is possible, but not less than a 90° arc of the mast arm.



*Figure 2.6 Mast Arm 2 After UIT Application.*



*Figure 2.7 Mast Arm 2 After UIT and Application of Zinc Rich Spray Paint*



*Figure 2.8 UIT Application at the bottom of Mast 2*

The end plate-mast arm weld toe was treated first via bucket truck. Next, the technician descended and applied the UIT at the base plate-mast weld toe. To save time, the TxDOT inspector used the bucket truck to inspect the UIT application at the end plate-mast arm weld toe while the base plate-mast UIT application was performed. After satisfactory inspection by the TxDOT inspector, the TxDOT inspector applied two coats of a zinc-rich paint. A flat-head screwdriver was used to scrape away galvanizing loosened by the UIT application as shown in Figure 2.8. Once the UIT application area was scraped clean 2 coats of zinc-rich paint were applied. The paint was Rust-oleum Cold Galvanizing compound, 93% pure zinc.

The inspector then descended to inspect the base plate-mast weld UIT application and apply the zinc-rich paint. To save time, while the TxDOT inspector was inspecting and painting the base plate weld, if there were more structures to be treated at the same intersection, the bucket truck was moved to the next UIT application location.

## **2.4 Inspection**

The inspector looked for a continuous application of UIT, meaning that the visible application was an unbroken line from start to finish. The inspector also visually confirmed that the UIT extended 45 degrees in both directions from the top of the weld.

## 2.5 Application Times

The UIT applications of Mast arm 1 and 2 began at 10:17 am and finished at 11:11 am. The application times are shown in Table 2.1. The average time from arrival at site to departure from site is approximately 35 minutes. Total time at a site is not always just the addition of total times at the masts and the mast arms, since UIT application to the mast base begins while painting was applied to the mast arm.

*Table 2.1 UIT Application Times*

Location	Time (min)					Total Time
	Setup	UIT Application	Inspection and weld cleaning	Galvanization repair	Clean up	
Mast arm 1	11	6	2	3	2	<b>24</b>
Mast 1	-	6	3	4	0	<b>13</b>
					<b>Total</b>	<b>33</b>
Mast arm 2	5	6	2	3	2	<b>18</b>
Mast 2	-	7	3	4	4	<b>18</b>
					<b>Total</b>	<b>36</b>

## 2.6 Miscellaneous Observations of Field Operations

Morning operations were stalled for 2 hours because the bucket truck was late getting to the site due to trouble locating a generator. The generator was needed to supply the power to the UIT equipment.

The bolts used on Mast arm 2 interfered with UIT application, so the technician applied UIT as best as possible, and the TxDOT inspector found the application to be adequate. The UIT should be applied at a 45° angle each side of vertical, however this was not always possible and the UIT was applied as closely to a 45° angle as possible. The TxDOT inspector suggested using the UIT tool with a 15° angle that is available, but it was decided that technicians in the field would be unlikely to switch to a 15° angle UIT tool; therefore, the straight UIT machine was used in an effort to simulate typical field applications as accurately as possible.

The most common problem during the UIT applications was keeping the power generator running. It was discovered after UIT application that the power generator was on an angle, which caused the engine to flood. The power generator, the UIT generator, and the water cooler stayed in the truck during UIT application. The UIT tool has a 50-foot cord which facilitated application to the mast arm welds.

The TxDOT inspector also had slight problems applying the zinc-rich paint in the field due to excessive wind, but this never slowed treatment for more than a minute.



## **Chapter 3: Laboratory Fatigue Test of Mast Arms**

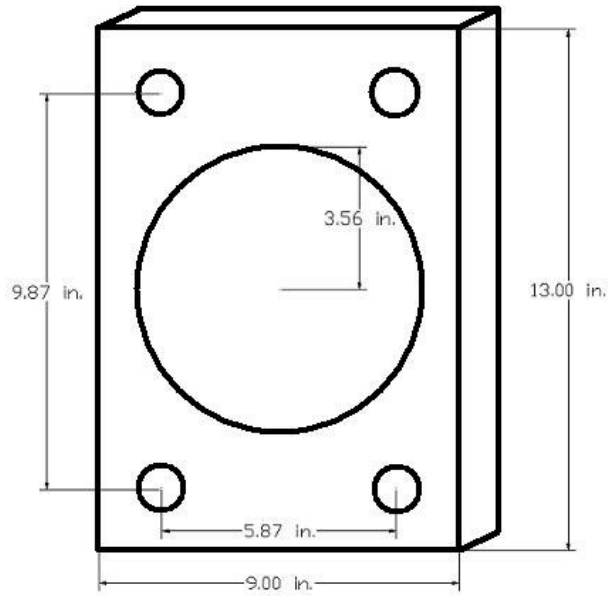
### **3.1 Introduction**

To determine the effectiveness of UIT retrofit, two mast arms were removed from the site and tested. One mast arm had been retrofitted by UIT, and the other had not been retrofitted. The study was undertaken to determine the effectiveness of field UIT applications to in service mast arms. Denton, where the UIT retrofit described in Chapter 2 was performed, was selected as the location for obtaining the test specimens. Signal structures in this area had suffered fatigue failures and had been observed to undergo large oscillations. Two mast arms at the same location with similar load histories and the same geometry were not available. It was decided, due to logistical considerations and the availability of replacement mast arms, to test two mast arms from the same intersection but with different geometries.

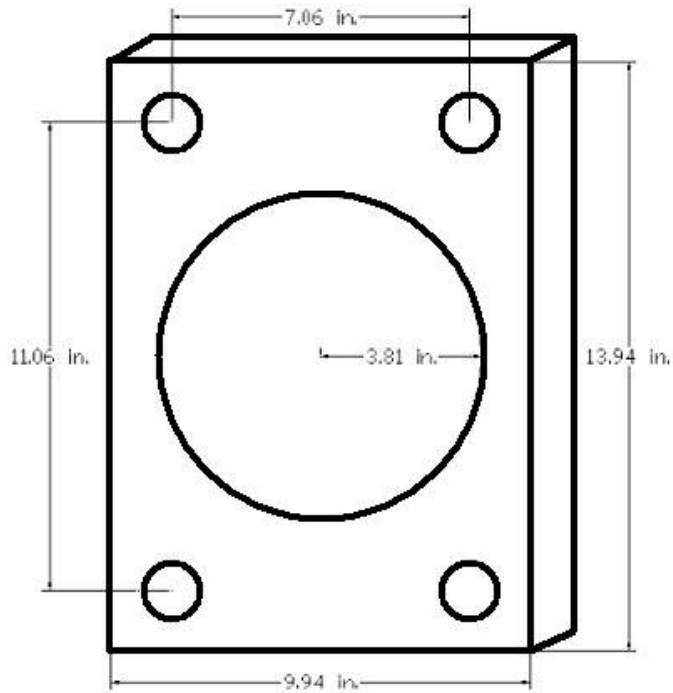
### **3.2 Test Specimen Geometry**

The mast arm specimens to test UIT retrofit effectiveness were taken from the intersection of I-35E and Bonnie Brae Street in Denton, TX. Figure 2.1 in Chapter 2 shows a satellite photograph of the intersection. The mast arm labeled mast arm 1 in Chapter 2 was removed for laboratory testing. Both the weld toe on the arm and the end plate were treated in the field with UIT as described in Chapter 2. This mast arm was removed from the field 5 months after UIT application, and will be referred to as mast arm DU. The “D” refers to “Denton” and the “U” refers to “UIT”. The mast arm from the Northwest corner of the North intersection was not treated by UIT. The untreated mast arm from the Northwest corner will be referred to as mast arm DN. The “D” refers to “Denton” and the “N” refers to “No UIT”.

Mast arm DU was a 24-foot mast arm with thickness of 0.152 inch after removal of galvanizing, and a diameter of 7-1/2 inch at the 1 in. end plate. Mast arm DN was a 28-foot mast arm with thickness of 0.148 inch after removal of galvanizing, and a diameter of 8 inch at the 1-1/4 in. end plate. Figure 3.1 shows the dimensions of the mast arm DU endplate, and Figure 3.2 shows the dimensions of the mast arm DN endplate. The difference in end plate thickness and hole pattern as well as the difference in the arm diameters made comparison of the test results difficult.



*Figure 3.1 DU Mast Arm Endplate Dimensions, 1 in. Thick*



*Figure 3.2 DN Mast Arm Endplate Dimensions, 1-1/4 in. Thick*

The mast arms were cut down to 85" to fit into the test setup, and had 10" x 10" x 1" steel end plates welded to the ends. The mast arm specimens were then connected to the load box by approximately 1 foot long all-thread rods. Mast arm DU required 1" all-thread rods, and mast arm DN required 1-1/4" all-thread rods. In order to define the location of load transfer between the end plate and the load box, washers were placed on the all-thread rod between the baseplate and the load box. Aside from preventing prying, the washers also provided a known load path between the base plate and the load box. With the washers in place, the load was transferred directly at the bolt hole of the end plate, and not at any other location around the baseplate.

This eliminated any rocking of the baseplates due to out of flatness of the plates. Also, the washers were cut at angles to allow the angled mast arms to be horizontal at zero load when connected to the load box. A picture of the baseplate connected to the load box with the beveled washers is shown in Figure 3.3. Notice in Figure 3.3 that the top washer between the baseplate and the load box is longer than the bottom washer to level the test specimen. The washers are beveled to match the angle of the baseplate.



*Figure 3.3 Beveled Washers Used Between End Plate and Loading Box*

### 3.3 Static Tests

Static tests were performed prior to dynamic testing of specimens DU and DN. All tests were cycled between a minimum and maximum displacement that corresponded to the loads that would induce the desired stresses at the mast arm weld toes. Loads were calculated from the dimensions of the mast arm at the mast arm weld toe. Using the outer diameter,  $D_o$ , and inner diameter,  $D_i$ , the moment of inertia at the weld toe,  $I$ , can be calculated from the equation:  $I = \pi/64*(D_o^4 - D_i^4)$ . Knowing the desired maximum and minimum stresses, and the distance from the centroid to the extreme fiber,  $c = D_o/2$ , the moment at the weld toe,  $M$ , can be calculated from the equation:  $M = \sigma*I/c$ . Using this data along with the length of the moment arm (the distance from the end support to the weld toe),  $l$ , the loading actuator load,  $P$ , corresponding to the desired stress can be calculated by the equation:  $P = 2*M/l$ .

The outer diameter of the test specimens was measured using either outer diameter calipers or measuring tape. The inner diameter was assumed to be the difference of the outer diameter and twice the thickness,  $t$ , which can be described by the equation:  $D_i = D_o - 2*t$ . The thickness was measured from scrap pieces of the shortened specimens before calculations were made. The thickness was measured with digital calipers after removal of galvanizing with nitric acid.

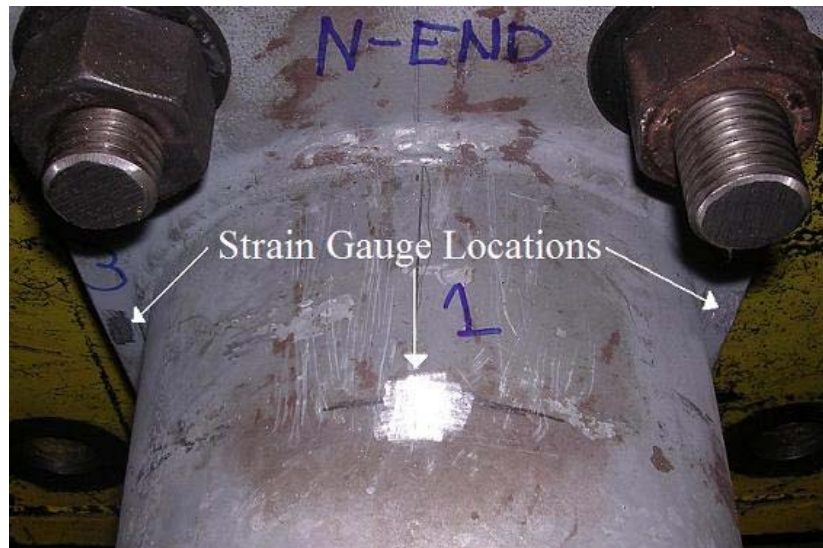
The desired stress range for the smaller specimen DU was 12 ksi with a minimum stress of 16 ksi. The calculated minimum load was 2.30 kip and the maximum load was 4.03 kip. The result was a lower stress range on specimen DN, the untreated specimen. Table 3.1 shows the test loads and nominal stress ranges.

*Table 3.1 Summary of Calculations for Specimens DU and DN*

	Specimen	
	DU	DN
Diameter <sub>outer</sub> (in.)	7.5267	7.9626
Diameter <sub>inner</sub> (in.)	7.2227	7.6666
thickness (in.)	0.152	0.148
Length (in.)	88.5	88.5
I (in <sup>4</sup> )	23.95	27.75
P <sub>min</sub> (kip)	2.30	2.30
P <sub>max</sub> (kip)	4.03	4.03
stress <sub>min</sub> (ksi)	15.99	14.6
stress <sub>max</sub> (ksi)	28.02	25.6
stress <sub>range</sub> (ksi)	12.03	11.0

After specimens DU and DN were secured in the test setup, the mast arms were subjected to static loading from 0 kip to the maximum load of 4.03 kip and back to 0 kip in 1 kip increments. During the static test, displacements and strains were measured. The static test also included measurements at the minimum load of 2.30 kip.

Strain gauges were attached at the top of the mast arm 3 inches from the weld, and at the mid-height of the baseplate on either side. Locations of the strain gauges are shown in Figure 3.4.



*Figure 3.4 Locations of Strain Gauges*

The results of the strain measurements at 3 inches from the mast arm-base plate weld were within 7.8% of the expected strains for the DU specimen and within 15.8% of the expected strains for the DN specimen. Figure 3.5 is a plot of load vs. strain for the DU static test, showing both measured and expected strains. Figure 3.6 is a plot of load vs. strain for the DN static test, showing both the measured and expected strains. Since the strain gauges were attached 3 inches from the mast arm weld toe, expected strains were calculated using the moment arm and diameter at the location of the strain gauge. The variation of the measured strain from the calculated strains is due to the local bending of the mast arm tubing wall due to the deformation in the end plate.

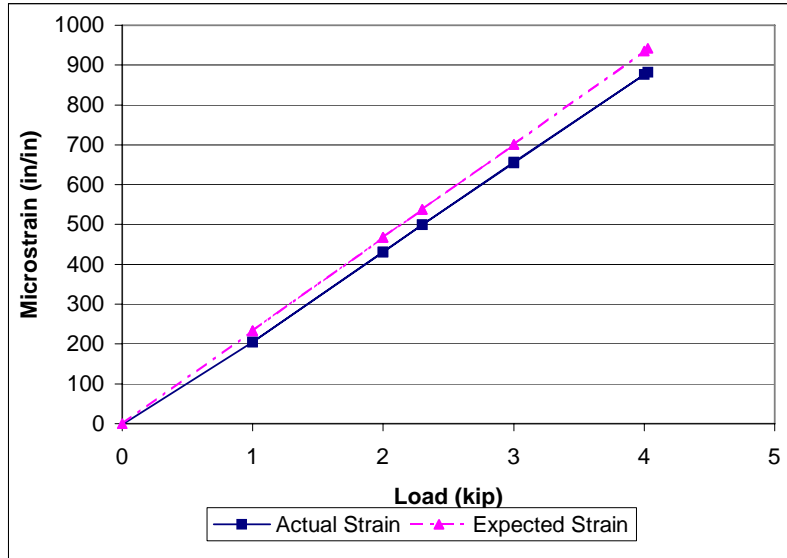


Figure 3.5 Actual and Expected Strain at 3 Inches from the Mast Arm Weld Toe of Specimen DU

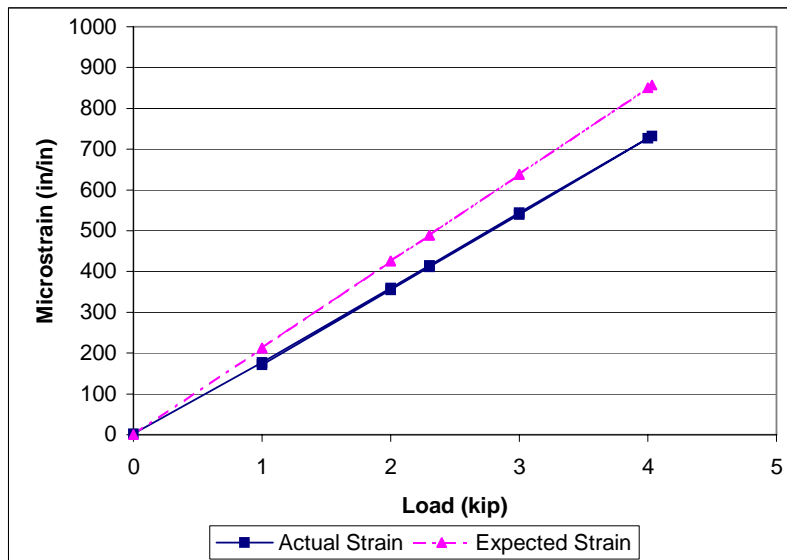


Figure 3.6 Actual and Expected Strain at 3 Inches from the Mast Arm Weld Toe of Specimen DN

Limited analytical studies at the University of Texas at Austin into the effects of end plate thickness on mast arm fatigue life have been performed and further work is underway [1]. In an effort to gather information for future research, strains were also measured along the mid-height of the end plate during static tests to measure the bending strains in the end plates. Figure 3.7 shows the strains on both the East and West side of the mid-height of the DU end plate.

Figure 3.8 shows the strains on both the East and West side of the neutral axis of the DN end plate. Notice that the DU end plate has strains ranging to 225 in/in at 4.03 kip, while the thicker DN end plate has strains ranging to only about 61 in/in at 4.03 kip. The DU end plate was only 1 inch thick, while the DN end plate was 1-1/4 inches thick. The additional 1/4 inch of the DN end plate increases the stiffness of the end plate that reduces the stress at the mast arm weld toe.

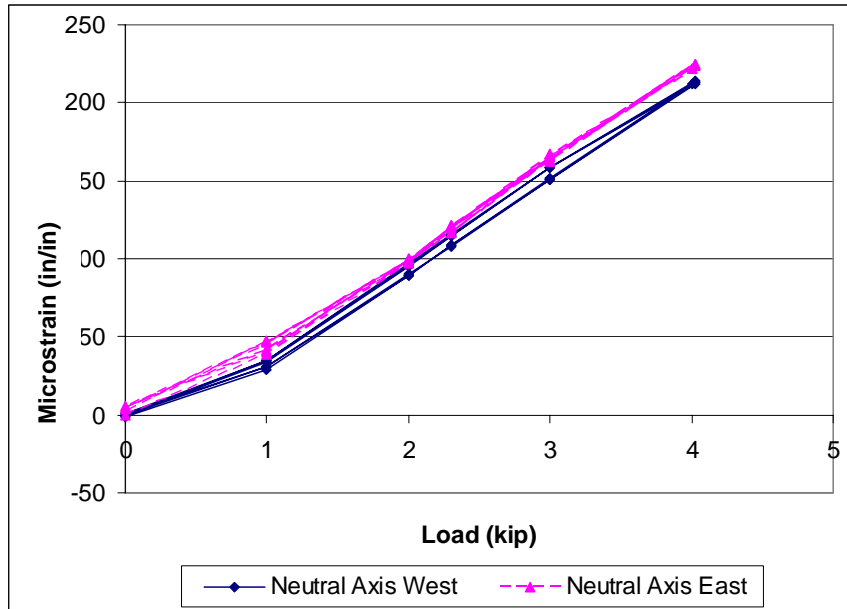


Figure 3.7 Strain at the Mid-Height of Baseplate DU

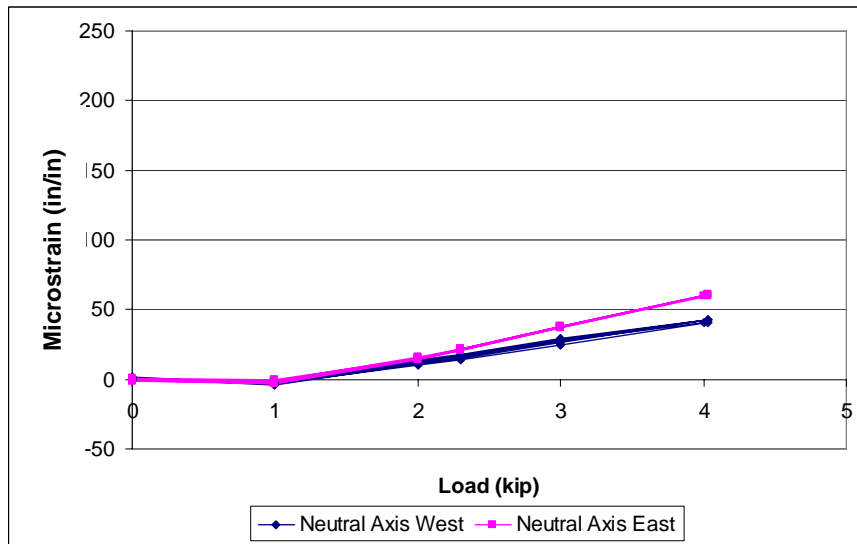


Figure 3.8 Strain at the Mid-Height of Baseplate DN

### 3.4 Fatigue Tests

The dynamic loads were based on specimen DU's geometry and the desired stress range of 12 ksi, from a minimum stress of 16 ksi to a maximum stress of 28 ksi at the mast arm weld toe. The dynamic test was performed under displacement control. The displacements for the dynamic test were determined during static tests. There were three phases to the dynamic testing. The first dynamic test phase, Phase 1, cycled both uncracked mast arms DU and DN from 2.30 kip to 4.03 kip. The second dynamic test phase, Phase 2, cycled the uncracked DN mast arm, and the DU mast arm after weld repair from 2.30 kip to 4.03 kip. The third dynamic test phase, Phase 3, cycled the still uncracked DN mast arm, and the DU mast arm after weld repair and the addition of a stiffener, from 2.30 kip to 4.03 kip.

Table 3.2 gives the maximum and minimum loads and deflections during all three phases of dynamic testing. The differences in displacements are due to changes in stiffness of the repaired specimen. Limits were determined to be approximately a 5% addition to the maximum load and deflection and approximately a 5% drop from the minimum load and deflection.

*Table 3.2 Maximum and Minimum Loads and Deflections During Dynamic Testing*

Phase:	Phase 1		Phase 2		Phase 3	
Duration (cycles):	0 - 90,680		90,680 - 116,876		116,876 - 224,905	
	Min	Max	Min	Max	Min	Max
Load (kip)	2.30	4.03	2.30	4.03	2.30	4.03
Deflection (in)	3.175	3.625	3.091	3.543	2.832	3.216

The testing conditions of Phase 1 lasted until mast arm DU developed fatigue cracking that lowered applied loads below the limits at 90,680 cycles. A close-up of the fatigue cracks in the DU mast arm weld toe along the UIT application line is shown in Figure 3.9. Figure 3.10 shows the entire fatigue crack on mast arm DU after highlighting with a red marker.



*Figure 3.9 Close-up of Fatigue Crack on Specimen DU Mast Arm Weld Toe Along the UIT Application Line (90,680 cycles)*



*Figure 3.10 Highlighted Fatigue Crack on Specimen DU Mast Arm Weld Toe Along the UIT Application Line (90,680 cycles)*

The fatigue crack in specimen DU was repaired by grinding away the galvanizing and re-welding the fatigue crack. The mast arms were then cycled between maximum and minimum load at 0.08 Hz to determine the displacements for Phase 2 of the dynamic test.

The testing conditions of Phase 2 lasted until a new fatigue crack on mast arm DU occurred through the weld repair at 116,876 cycles. A close-up of the second fatigue crack in the DU mast arm weld toe through the weld repair is shown in Figure 3.11.



*Figure 3.11 Close-up of Fatigue Crack on Specimen DU Mast Arm Weld Toe Along the Weld Repair (116,876 cycles)*

After the failure of the weld repair on mast arm DU, it was decided to add a stiffener to mast arm DU, to reinforce the weld and prevent further fatigue cracking. Figure 3.12 shows the stiffener added to mast arm DU before Phase 3 dynamic testing.



*Figure 3.12 Stiffener Added to Mast Arm DU After 116,876 Cycles*

The testing conditions of Phase 3 lasted until mast arm DN developed a fatigue crack at 224,905 cycles. A close-up of the fatigue crack in the DN mast arm weld toe is shown in Figure 3.13. Figure 3.14 shows the entire fatigue crack on mast arm DN after highlighting with a red marker.



*Figure 3.13 Close-up of Fatigue Crack Along Mast Arm Weld Toe of Specimen DN (224,905 cycles)*



*Figure 3.14 Highlighted Fatigue Crack Along Mast Arm Weld Toe of Specimen DN (224,905 cycles)*

### **3.5 Fatigue Test Results**

Since mast arms DU and DN did not have the same mast arm thickness, mast arm diameter, end plate thickness, bolt hole spacing, and test stress range, the best way to compare the fatigue test results is to compare them with specimens with similar geometry in an S-N chart. Figure 3.15 shows an S-N chart of DU and DN on the same plot, along with AASHTO fatigue Categories. Both axes are log scales.

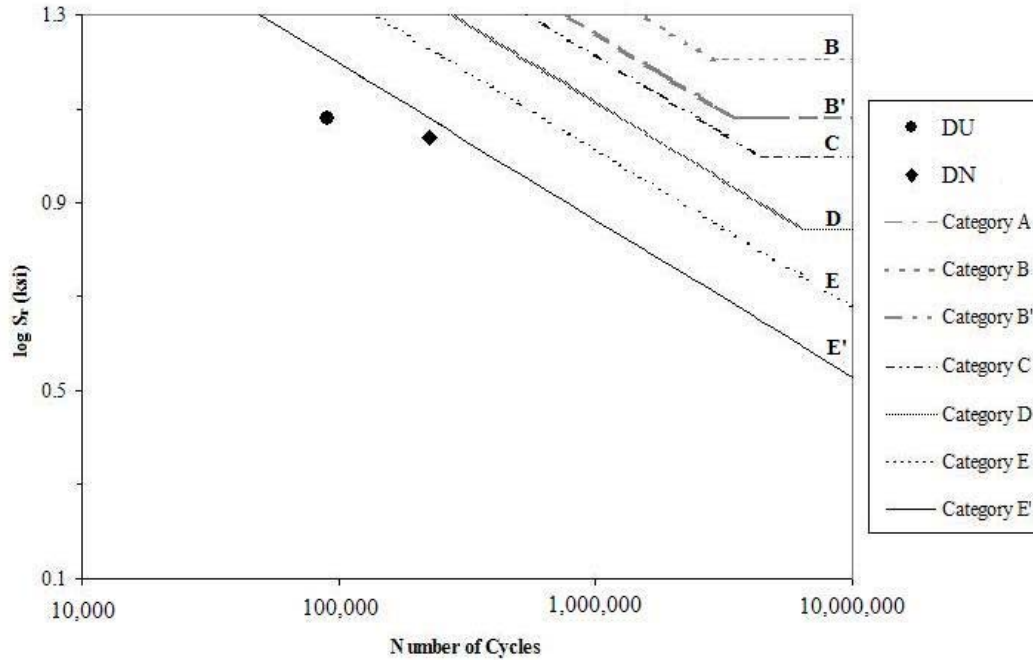


Figure 3.15 S-N Plot of DU, DN, and AASHTO Fatigue Categories

Figure 3.15 shows that neither mast arm DU nor mast arm DN reached Fatigue Category E'. The S-N plot for mast arm also shows that DN had a slightly better fatigue resistance than DU. These results do not indicate that field UIT retrofit of specimen DU improves its fatigue performance as much as expected. However, the difference in base plate thickness and arm size between these two specimens makes it impossible to directly compare these test results.

### 3.6 Field UIT Application vs. Fabrication Yard UIT Application

Fatigue testing was conducted at Ferguson Laboratories at the University of Texas at Austin on mast arms from TransAmerican facility [2]. These tests were selected to compare with the field applied UIT specimens since they had similar base plate thicknesses and bolt geometry. Tests included mast arms with and without UIT. Mast arms with UIT had UIT applied at TransAmerican's facility. Table 3.3 lists the fatigue results of the mast arms from TransAmerican and Denton, TX. Mast arms with UIT application at the fabrication yard are labeled TAU. Mast arms without UIT from TransAmerican are labeled TA. Figure 3.16 shows the S-N plot comparing mast arms with UIT applied in the fabrication yard to mast arms with UIT retrofit in the field.

Table 3.3 Test Results for TA Series, TAU Series, DU, and DN

Specimen Name	Stress Range (ksi)	Mast Arm D <sub>o</sub> (in.)	Number of Cycles	UIT?	End Plate Thickness (in.)
TA A	12	10	75,121	No	1.25
TA B	12	10	59,196	No	1.25
TA C	12	10	44,771	No	1.25
TA D	12	10	62,026	No	1.25
TAU A	12	10	263,044	Yes	1.25
TAU B	12	10	246,045	Yes	1.25
DU	12	7.5	90,680	Yes	1
DN	10.9	8	224,905	No	1.25

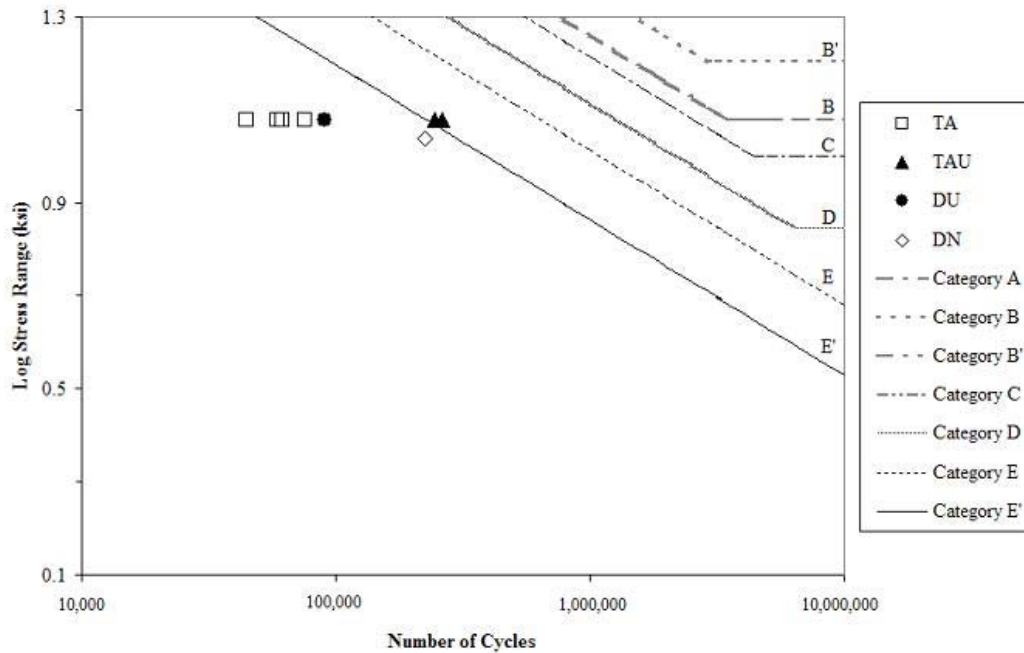


Figure 3.16 S-N Plot for DU, DN, and the TAU Series

As can be seen in Table 3.3 and Figure 3.16, UIT application at the fabrication yard increased fatigue life of TransAmerican mast arms to above Category E'. Mast arm DN that was not treated produced a fatigue life that was comparable to the TAU specimens. Mast arms DN and TAU have the same end plate thickness but the diameter of mast arm DN is smaller than TA

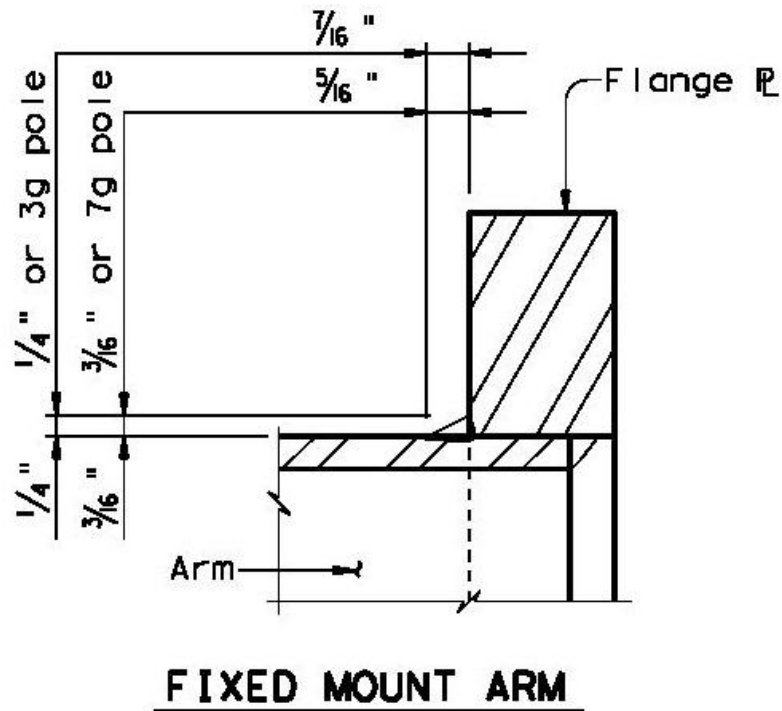
specimens. The moment in the end plate and mast arm are smaller in the DN specimen than the TA specimens for the same stress range. Consequently, the deformation in the end plate would be less in the DN specimens which is thought to reduce the stress at the weld toe. Mast arm DU, with a thinner end plate, did not see the same improvement in fatigue life as the TAU specimens at the same stress range. However, since geometric properties vary between the specimens, a direct comparison cannot be made. It is likely that a specimen with the same geometry as DU might produce a shorter fatigue life than the TA specimens due to its thinner end plate. More tests, involving specimens with the same geometries, should be conducted to allow for accurate comparisons.

It is also worth noting that both TAU specimens developed unusual fatigue cracking along the untreated weld toe. This unusual crack development was discussed in Section 2.3. From the investigations of TAU specimens' fatigue cracks, it has been recommended to apply UIT to both weld toes to prevent unusual fatigue cracking in the future.

### **3.7 Weld Toe Geometry**

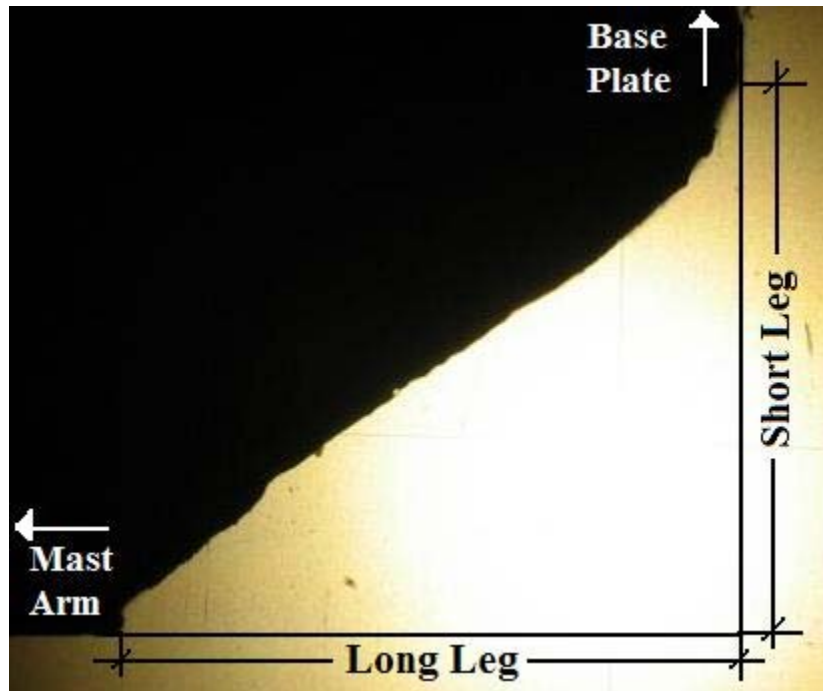
Another important factor in fatigue resistance of a weld is weld toe geometry. Previous research shows that UIT increases the toe radius and introduces an undercut for softer metals [3]. UIT improvements on weld toes lower the stress concentration at the weld toe [4].

TxDOT specifications for mast arm welds are found in TxDOT Standard MA-C-96: Standard Assembly for Traffic Signal Support Structures. The dimensions for the standard mast arm-baseplate weld are shown in Figure 3.17 which is taken from TxDOT Standard MA-C-96. As shown in Figure 3.17, the long leg of the weld should be  $7/16''$ , and the short leg should be  $1/4''$ , giving a weld angle of  $30^\circ$ .



*Figure 3.17 Standard Mast Arm-end plate Weld Dimensions from TxDOT Standard MA-C-96*

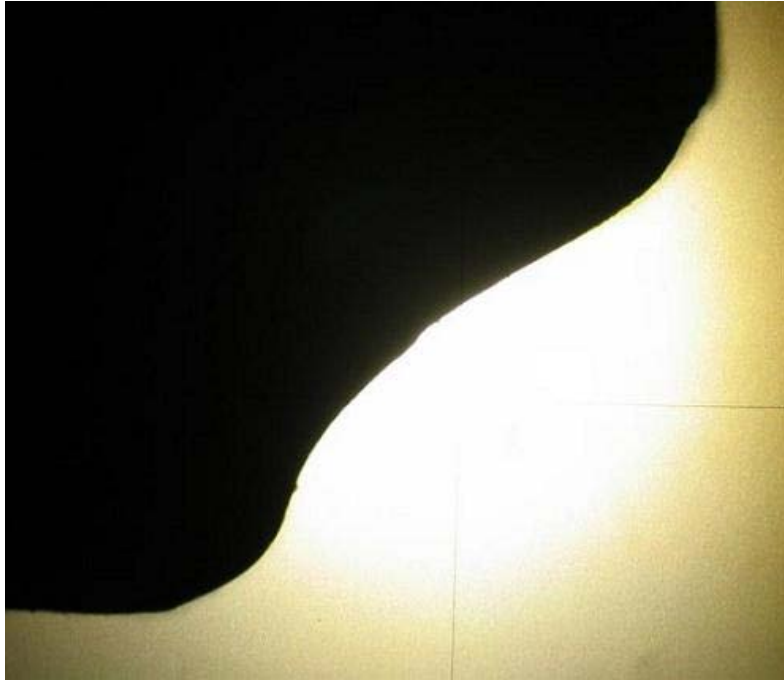
Molds were made of mast arm weld profiles before and after UIT application. The molds were made as described in reference 1. Figure 3.18 shows a typical weld, pointing out the locations of the long and short leg. All measurements of the weld legs were made with the Mitutoyo Profile Projector, Model PJ250. The Profile Projector projected a 10x magnification of the weld mold onto a screen with cross hairs. From this projection, a digital readout with accuracy of 0.0001 inch was used to measure the lengths of the weld legs. Figure 3.19 shows the weld profile of a typical mast arm at 10x magnification.



*Figure 3.18 Typical Weld Leg Locations*



*Figure 3.19 10x Magnification of Mast Arm Weld Before UIT*



*Figure 3.20 10x Magnification of Mast Arm DU Weld After UIT*

Figure 3.20 shows the weld profile of mast arm DU after UIT Application at 10x magnification. Comparison of weld toe regions in the two figures clearly shows the effect of UIT on weld toe profile. Previous research determined that UIT produces an increased radius at the weld toe [1,4].

The weld toe geometries for specimen DU, a typical untreated weld, and TxDOT specifications are listed in Table 3.4. The global angle is the angle between the long leg and the hypotenuse, taken as the arctangent of the short leg/long leg. Note that the weld is not a smooth shape with a constant cross section. Variations of at least 0.01 in. in weld size are expected.

*Table 3.4 Weld Toe Geometries*

Weld	Average Values		
	Short Leg (in)	Long Leg (in)	Global Angle (°)
DU After UIT	0.318	0.338	43
Typical Untreated Weld	0.344	0.386	42
Specification	0.1875	0.3125	31

UIT application decreases the length of the legs, but this has a negligible effect on the global angle of the weld. The local angle at the weld toe is reduced due to the radius created by the UIT.

## **Chapter 4: Summary and Conclusions**

### **4.1 Field Application of UIT**

Application of UIT in the field was performed easily using a bucket truck. Minimal traffic disruption occurred and the time required was less than 40 minutes per arm. The process requires an electrical power generator which must be supplied with the bucket truck and suitably located to prevent problems during operation. The weld toes on both the mast arm and end plate should be treated to extend the fatigue performance. The treatment should include at least an arc of 90 degrees but no more than 180 degrees centered on the top of the mast arm. The connection bolts can prevent access to the full 180 degrees. In all the laboratory tests the cracks of treated and untreated welds always started at the top of the mast arm, therefore treatment of the lower compression portion of the arm is unnecessary. The galvanizing should be repaired by spraying a zinc rich paint over the treated area. Zinc based solders which require heating of the treated area are difficult to apply and negate the improvement in fatigue life from UIT.

### **4.2 Improvement in Fatigue Performance**

The fatigue test of the one treated specimen did not produce the fatigue life found in previous laboratory tests of arms treated by UIT. The 1 inch end plate thickness of the specimen treated in the field was substantially less than the 1-1/2 thick end plates used in the previous laboratory tests. The mast arm treated in the field produced a fatigue life comparable to untreated specimens with a thicker 1-1/4 end plate which indicates that some improvement was attained through the field UIT. End plate thickness plays a major role in the fatigue performance of the socketed end plate connection; however UIT appears to improve the performance of mast arms with thinner end plates when compared to the performance of those with thicker end plates. The good performance of the arm treated in the field is all the more remarkable since the prior damage caused by the in-service stress was ignored in the evaluation of its performance.

### **4.3 Conclusions**

The ease of performing UIT in the field makes the treatment of mast arm connection welds a viable method of improving the fatigue performance of mast arms that may be subject to galloping. Mast arms at intersections where an arm has failed and adjacent intersections are candidates for the application of UIT. This simple method can be used to extend the remaining life of the arms. Tests on cracked structures have shown that the effectiveness of UIT is negligible when a crack has already formed at the weld toe. Existing cracks will usually be found during a visual inspection of the weld toe at the time of the UIT application. Mast arms with visible cracks should be replaced.



## References

1. Koenigs, Mark T.; Botros, Tammer A.; Freytag, Dylan; and Frank, Karl H., Fatigue Strength of Signal Mast Arm Connections, Reserach Report 0-4178-2, Center for Transportation Research, The University of Texas at Austin, August 2003.
2. Freytag, Dylan; and Frank, Karl H., Fatigue Tests of Signal Mast Arms with Ultrasonic Impact Treated Welds, Test Report to Trans American Power Products, Ferguson Structural Engineering Laboratory, The University of Texas at Austin, May 3, 2004.
3. Galtier A, Statnikov ES. The Influence of Ultrasonic Impact Treatment on Fatigue Behaviour of Welded Joints in High-Strength Steel. *Welding in the World* 2004; 48(5-6):1-66.
4. Tryfyakov VI, Mikheev PP, Kudryavtsev YF. Ultrasonic Impact Peening Treatment of Welds an Its Effect on Fatigue Resistance in Air and Seawater. *Proceedings of the Annual Offshore Technology Conference*, part 4, 1993: 183-187.