

Shot Peen-Forming

R. J. D. Tatton

*Metal Improvement Company**Deeside**North Wales**UK*

ABSTRACT

Shot peening is a well established cold metal working process used to increase fatigue life and resistance to stress corrosion. Since the late 1940's the process has also gained world wide acceptance, mainly in the aircraft industry, as a method to form components. Most applications relate to aluminium alloy wing and fuselage machined skin panels, the first aircraft of which was the Lockheed Constellation. Current production aircraft includes Airbus Industrie A310 and A320, McDonnell Douglas MD80 and Rockwell B1. The panels are formed as a result of the compressive stress induced in the surface. The depth and intensity of this compressive stress can be varied to induce varying radii of curvature and/or to allow for varying thicknesses. As the form is induced by the stresses which result from the shot impact on the surface the process requires no dies. The principal tooling expense is for the profile checking media which, if properly designed, can be cheaply modified to suit design changes. This ensures that the initial tooling cost and construction time is minimal when compared with alternative methods and changes in design can be incorporated economically and quickly. Single and double curvature can be induced. An additional bonus from this forming method is that, due to the induced compressive stresses on both surfaces, the component's fatigue life is enhanced which is the opposite effect of most other forming processes.

INTRODUCTION

Shot peen forming is a technique developed since the late 1940's for forming integrally machined skin panels for aircraft fuselage and flying surfaces. The technique was evolved when it became evident that other commonly used methods were not feasible for the design concept then being initiated. Historically the basic structure used for metallic airframes was a development of the old method of wooden frames covered with cloth. The use of high strength aluminium alloys for the frame - composed of ribs and stringers - covered with shaped aluminium skins had become the universally adopted method by the end of World War II.

EARLY DESIGNS

At this stage of airframe development the skins were made from aluminium alloy sheet of constant thickness. The sheet material was formed either by press or stretch forming. Both methods permitted simple or compound shapes. Simple shapes are considered to be those with a curve in one direction and straight at right angles to that direction and compound as being curved in both directions. In addition simple shapes could be induced on wide 3 point rollers. The metallurgy and techniques used by the raw material manufacturers had developed so that large billets could be produced and it was realised by the airframe designers that considerable weight saving could be achieved if the skin complete with stiffeners and doublers could be machined from one piece of material. Clearly any joint in an airframe adds weight to the structure as the material has to be reinforced with doublers, triplers etc., to carry through the design service loads and then fastened together with attachment fasteners (rivets, bolts etc). Furthermore if the area in question is being used as a fuel tank - such as the wing box - then sealants must be carefully applied. All resulting in a labour intensive structure to manufacture which, due to the added weight, reduces the useful load carrying capacity of the aircraft. A major problem was that such a component would have to be machined in the flat and then be formed to the aircraft's contours. All the contemporary accepted methods of forming, as previously mentioned, were limited by the fact that they were only successful on sheet material of uniform thickness.

This was the predicament facing manufacturing engineers at Lockheed Aircraft Company with the then novel design being used for the major wing skin surfaces on the Lockheed Constellation aircraft. They were already familiar with the techniques of shot peening machined structural components to increase fatigue life and so were aware of the effect of shot bombardment on "Almen Strips". These strips are made from carbon steel and are 77mm by 19.2mm and 0.80mm, 1.31mm or 2.41mm thick according to specification requirements. One side only is peened and so causes a compressive stress in and near that surface. In balancing the stresses about the neutral axis the strip assumes a curve, the radius of which will vary with the size of the shot and its speed at the instant before impact and is convex on the peened side. (See Fig. 1). The Lockheed engineers wondered if this phenomenon held the clue to the solution to their forming problem. More specifically the wing skin panels had been designed to be 1m wide and around 12m long with a number of integrally machined stiffeners running the length of the panel. There were lands at various positions traversing the width of the panel to transmit loads between skin and ribs as well as access apertures with thicker lands surrounding them. The subsequent feasibility tests carried out in conjunction with Metal Improvement Company confirmed the viability of the method. Metal Improvement Company developed machines, equipment and techniques in conjunction with Lockheed who patented the process.

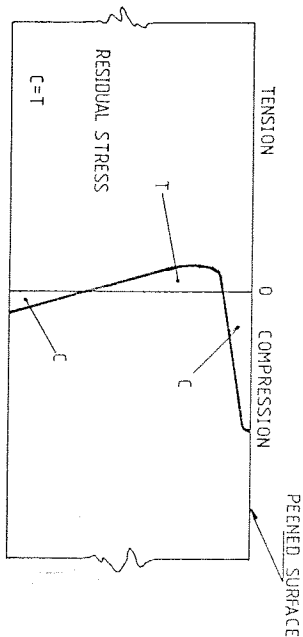

Fig. 1. Distribution of stress in a beam which has been shot peened on the upper surface with no external applied load. Since the beam is in equilibrium with no external forces the area under the stress distribution curve in the regions of compressive stress must be equal to the corresponding area under the curve in the region of tensile stress. Further, the sum of the moments, about this neutral axis, must be equal.

Since those early days the technique of shot peen forming has developed along with the expertise of the raw material manufacturer, advances in machining technology all under pressure from the aircraft designers and stressmen who are always trying to produce stronger and lighter designs with longer service lives. The latest designs are for skin panels up to 30m long machined on 5 axis N/C machines with machined integral doublers, the skin thickness varying in tapers and steps both along the width and length and with 'saddle' or 'barrel' compound shapes.

Machined and shot peened skin panels are now to be found on modern aircraft throughout the world. Such as on most Boeing jet transports, Lockheed C130, L1011, McDonnell Douglas DC9, DC10, MD80, Rockwell B1, Fairchild A10, BAe1-11, Concorde, Airbus Industrie A310 and, most recently, A320.

SHOT PEEN FORMING IN PRODUCTION

Once the basic design of a machined panel is established there are three distinct phases: Proof of Concept, First Article Development and Production Start-Up. These three phases will generally overlap - often because the pressures of the looming Production start-up telescope the phases together. Usually, however, the first articles are accepted as satisfactory by the responsible authorities of Design, Stress, Quality Assurance, Manufacturing Engineering before authorisation for full production start is permitted.

A description of the manufacturing stages of a typical machine sculptured shot peened aircraft skin with the emphasis on the forming operations will be of interest.

Current machining technology, using large numerically controlled milling machines, permits the design of minimum weight skins meeting optimum engineering requirements. To ensure minimum weight skins it is necessary to have the panel thickness tapering both across and along the length of a panel, combined with complex sculptured doublers, local pad areas and reinforcing lands around access apertures. These complex machining operations are readily achieved to great accuracy with modern multi axis NC milling machines. An interesting feature of such machines is that design changes, which are almost inevitable, can be economically achieved at a comparatively small cost by modifying the programme tapes, compared with the previously costly necessity to modify expensive hand tools of the earlier types of machines.

Shot peen forming is the technique whereby an unformed skin panel is bombarded with spherical steel shot. The shot is propelled with sufficient energy to cause permanent deformation at the surface on impact. The surface material is spread in the plane of the surface but the core is not and so resists this spreading. The surface is consequently under compressive stress. The core is in a corresponding state of tensile stress but, as the compressive stress is of a small depth compared to the tensile stress, the latter is of small magnitude. The skin then takes on a compound curved shape so as to balance these stresses. The peened surface is convex as it needs to expand to achieve this balance. Fig. 2 illustrates this phenomenon.

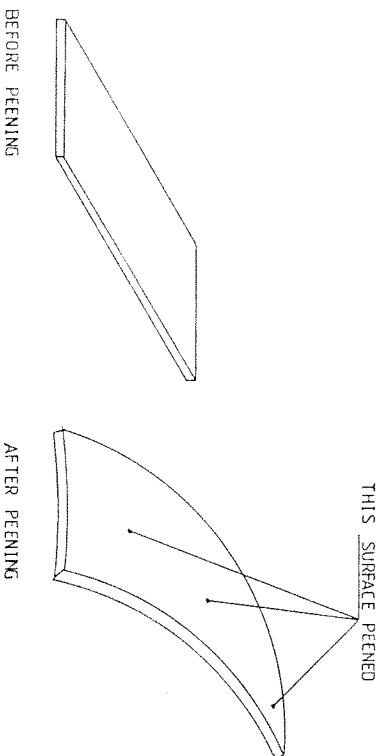
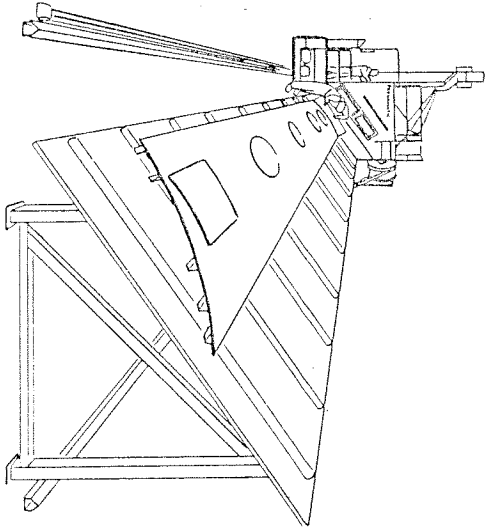

FIG. 2. If one side only is peened then that side will have a convex shape.



If the skin is long in one direction compared to the other (which is often the case) the panel will tend to stay straight in the long direction with the predominant shape in the width. Such simple shapes are readily achieved on panel forming machines such as the Peenamatic machine shown in Fig. 3.

Life, however, is not usually simple and aircraft designs are no exception. Wing skins in particular will often exhibit spanwise shape as well as the chord shape. So having induced the chordwise shape as already described it is then necessary to accommodate the spanwise shape. The span shape may be a fairly sharp change to accommodate a change in the dihedral or anhedral angle of the wing or a more gentle curve as is typically found on modern Airbus Aircraft the top surfaces are fairly straight spanwise but the lower surfaces have a concave curve from the thick wing root to just outboard of the engine mount, from which point the wing thickness reduces at a constant taper to the wing tip. For these more complex shapes correspondingly more complex techniques have been developed over recent years. One significant procedure has been "Pre-stress Shot Peening". It has been established that if the component surface is subject to a tensile stress whilst it is peened then the depth of the resultant compressive stress is increased. If this procedure is applied to both surfaces in a selective manner then the area so treated will increase in overall length compared to the unpeened condition. As a compound shape developed from the flat requires stretching of some areas compared to others this "Pre-Stress Shot Peening" technique if properly applied will give the required compound shape.

If the shape is "saddle back" as, for example, on the lower A310 and A320 surfaces as mentioned above - that is, convex in the transverse or chord direction and concave along its length (the span), then the edges of the panel in the compound area need stretching in relation to the central position of the panel. Conversely a "barrel" shape, that is, convex in both directions, requires stretching in the central region. It should be emphasised that when a part is pre-stressed great care is taken to ensure that the component's yield point is not exceeded. Usually a safety margin of at least 30% will be specified. This means that if the part is loaded in the pre-stress fixture and the load is then removed the part will spring back to its original shape. It is only if the part is shot peened whilst under this load that a permanent change of shape will occur.

There are several variables associated with shot peen forming that can be adjusted to vary the resultant degree of curvature and accommodate varying thicknesses or material strengths other than deciding to pre-stress or not. Firstly, the engineer has to decide what shot size to use. Typically, shot size will vary from 0.44 to 9.61mm diameter though smaller and larger sizes have and can be used. It should be noted that steel shot is used in preference to other materials due to its greater density and availability in comparatively large size. For very thin parts ceramic or glass beads may be used. The next decision concerns the shot energy at the moment of impact. The shot is propelled onto the part either by use of centrifugal wheels or compressed air peening nozzles. The energy, or speed, is controlled fairly obviously by adjusting the wheel speed or air pressure as required. The other control is the coverage of the part. Unlike other applications of shot peening 100% or more coverage is not necessarily for simple forming a component (reference to fatigue sensitive components is made later). This enables the engineer to select at a level below 100% as he requires. The properties of the component's material (yield, strength, hardness etc) may vary within its specification tolerances sufficiently to effect its response to shot peening. Partial coverage therefore, permits further work if required. To ensure even coverage has been attained at the levels required the use of 'Dyescan' is of great benefit. Dyescan is a fluorescent material in a volatile carrier that is sprayed or brushed onto the part and allowed to dry before shot peening. A shot particle removes the residue only at the area immediately under it upon impact. So examining the surface after peening with an ultra-violet light shows very clearly if the essential degree of uniformity has been achieved.

An aircraft skin profile must accurately follow the design contours to minimise in-built stresses caused by elastically straining the panel to shape upon assembly. The common profile checking gauge is a frame upon which a series of boards are mounted. Each board has its top edge machined or cut to the skin profile and, by controlling the height of the machined edge, the shape at right angles to the boards is defined. For the more critical areas, additional boards may be mounted at right angles to the first boards and so creating an "eggbox" gauge. The boards need to be far enough apart to enable reasonable access when the panel is resting on the boards. It is usual, in fact, for the boards to be positioned at the rib stations of the internal structure. The checking gauge is the only tooling specific to the component that is needed for shot peen

forming as the process requires no dies, punches or similar expensive tools necessary for press or stretch forming. Contour or geometric changes can therefore be easily accomplished as the only changes to hardware will be simple modifications to the boards on the checking gauge.

When the panel has been formed to the overall shape, unexpected problems do occasionally arise for the unwary. Two examples of what can happen follow:

If the part has been formed to a compound shape a geometric error in its plan profile may be shown on the checking gauge if the gauge has, as it should have, datum points marked on it. This can be due to different degrees of stretching on the edges of the panel, which may be required if the shape is an asymmetric saddle back, for example. The ideal solution is to modify the NC machining tapes to introduce a compensating swing in the opposite direction. Alternatively, and particularly in the short term on panels already machined, the swing can be corrected by introducing a stretching pattern across the width of the panel at an appropriate point.

The other example of post forming problems is that the panel's length will be increased by shot peening. The increase or "growth factor" is typically in the order of 6mm over 15m. This can be a problem on longer panels being assembled into jigs with fixed location points at either end. The only cure for this is by modifying the machining parameters to compensate for the growth.

Shot peening inherently produces a rough surface finish. The rough surface does not necessarily degrade the performance of the part due to the concomitant compressive stress, though this can be in conflict with the commonly accepted and over simplified philosophy of "smooth is good, rough is bad". There are, however, occasions when the rough "peaky" nature of a shot peened surface gives the designer problems. The surface finish may be such that the induced aerodynamic drag is unacceptable or, on the inside face, fretting will damage the paint at a joint face which could result in corrosion of both parts. It is quite common, therefore, to improve the surface finish in selected areas, or all over, by vibratory or other sanding machines or tools. It is, of course, important that no more material than necessary is removed and a good criteria is to sand until only the centre of the dimples are visible - but no more. Under such conditions it is most unusual for any significant relaxation of the shape to occur. Metal removal is unlikely to exceed 0.08mm per side after the most intensive shot peening and 0.03mm is more typical.

As aircraft skins are critical fatigue sensitive parts the designer will usually specify that the panels be saturation shot peened after the forming operations are completed to ensure all surfaces are subject to beneficial compressive stresses. Saturation peening is where the dimples or impressions in the surface are totally overlapping, that is 100% or more coverage. The intensity of this peening must be such that no significant change in shape occurs. This is usually quite easily achieved whilst, at the same time, inducing an adequate depth and magnitude of

compressive stress to ensure an acceptable fatigue life.

Before the panel goes on for surface treatments such as anodising, alodrom (alodyne in the USA) paint etc., it is necessary to ensure that any possible iron contamination on the aluminium alloy from the steel shot is removed as the iron could be a source of bi-metallic corrosion. Metal Improvement Company have developed a dilute acid/alcohol/water solution which can be sprayed onto the panel and then rinsed off. This method is far more economical on large components than alternatives such as alumina blasting etc.

An engineer now considering the use of shot peen forming on a major component of an aircraft can be reassured by the knowledge that a lot of experience had now been gained in this technique, particularly at Metal Improvement Company who now have been shot peen forming aircraft skins for over 35 years. Most aircraft, however, have novel features, or particular combinations of features that make its particular configuration and material combinations unique. The first stage therefore is for the forming specialist to evaluate designs at the earliest possible time. Each feature is divided into various categories such as: state of the art, extensions to the state of the art, areas of potential difficulty, new alloys/temper, contours, dihedral breaks, magnitude and rates of thickness variation, edge geometry and so on. This evaluation will give the project team a degree of confidence in the proposed procedures and establish what specific objectives a development exercise should have.

The general objectives will be initially to determine the feasibility of shot peening to form the component as designed. This first objective will be achieved in part by consideration of past experience combined with a test programme on either reduced scale test pieces, full sized panels or sections of panels or some combination of all 3. The second objective will be to determine the viability of the final article. It would, for example, be necessary for the designers to be satisfied that the effect on the mechanical properties resulting from the possible combinations of alloy, temper, thickness, shot size, shot coverage and peening intensity would result in an acceptable component on a regular production basis. Such an exercise will require the manufacture and testing of various test coupons, representative structures and even the destructive testing of an entire wing or complete aircraft. It should be realised that when major structures such as wings are made just for testing then a lot of factors other than the effect of shot peening are being determined.

At the end of this extensive development programme certain definite targets will have been achieved:

- The basic design will be fixed
- Procedure specifications will have been written and approved or, if already in existence, possibly amended according to the test results.
- A technique sheet prepared by the manufacturing engineers and approved by Design and Quality Assurance.

- Profile checking gauges will have been manufactured, installed and certified as accurate.

The Technique sheet may in fact be subject to revision after production experience has been gained on, say, 3 to 12 panels. Once, however, the definitive issue is approved it will require a very good reason for any changes to be accepted.

Components in a production run will vary in some small degree from each other due to variations in proof stress, dimensions and so on, within specification or design limits. Consequently some parts will respond to the forming operations more readily than others. Minor shot peen forming operations may be necessary on the checking gauge with controlled mobile equipment to finally bring the part to the required shape. It is, therefore, necessary to design the gauge so that such operations can be performed efficiently and quickly. This will entail designing a robust gauge with sufficient space in between the easily removable boards.

The first production panels will be subject to very close scrutiny principally by Quality Assurance but also by Design and Stress Office personnel wishing to assure themselves that all is well. Such scrutiny may extend, on a diminishing scale, to further production parts to ensure that a consistent standard is being and can be maintained. As a result of the First Article Inspection and the preceding development programme, a schedule of inspection procedures will be drawn up and agreed to by Design, Manufacturing and Quality Assurance for shop floor inspection to observe and perform on all production panels.

As previously mentioned the three phases, Proof of Concept, First Article Development and Production Start-up can be, and often are, somewhat telescoped together due to fixed programme milestones. In practice, however, it is essential that the bulk of each phase is complete before the next is underway, which results in a time consuming programme of work for a large number of people, often scattered across several locations many miles apart. Coordination and cooperation between all concerned is essential for a successful conclusion of a project that will take a minimum, for example in the case of a new wing design, 18 months and more likely 2 to 2½ years.

DISTORTION CORRECTION

Another application of shot peen forming not so far mentioned is the correction of distortion of machined components such as stringers, ribs and brackets. These types of parts may distort through the removal, during machine operations, of material with residual stresses induced by previous operations such as rolling, extruding, forging and heat treatment. Distortion can also be caused by the residual stresses induced by the machining itself. Over the last 20 years there has been a considerable increase in the proportion of internal airframe structures that are made from machined parts and so the problem of distortion has become more significant. This problem is not, however, restricted to the aerospace industry. As the distortion is not evident

until after the machining operations are complete a considerable investment in time, material and money has been made. Furthermore in the case of the more exotic alloys it may be some while before more material can be procured. In these cases correction by bending in a press or similar machine is often not practical and, more importantly, totally unacceptable to the designer due to the residual tensile stresses that will be induced into the part. In these cases selective shot peen forming is the ideal solution. It is economical, quick and induces beneficial compressive stresses in the worked area.

CONCLUSION

Finally, designers and engineers contemplating shot peen forming for the first time can be assured that there is no known service related problems with shot peen formed aircraft skin panels attributable to the technique of shot peen forming.

REFERENCES

1. Johnson J.R. and Daly J.J., Metal Improvement Company. Shot Peening takes an expanding role, 1975.
2. Nachman G. Metal Improvement Company, How to improve metal fatigue life, 1982.
3. Metal Improvement Company, Shot Peening Applications 6th. Edition, 1980.
4. Fuchs H.O. Stamford University, The effect of self stress on high cycle fatigue, 1982.
5. Moore D. McDonnell Douglas Canada Limited, The Application of Shot Peen Forming technology to Commercial Aircraft wing skins, 1982.
6. Skinner R.D. Lockheed California Company, Stress-Peen straightening of complex machined aircraft parts, 1979.