

INCH-POUND

MIL-S-13165C
7 June 1989
SUPERSEDING
MIL-S-13165B
31 December 1966

MILITARY SPECIFICATION

SHOT PEENING OF METAL PARTS

This specification is approved for use by all Departments and Agencies of the Department of Defense.

1. SCOPE

1.1 Scope. This specification covers procedure requirements for shot peening of metal parts, to induce residual compressive stresses in specified surfaces, for the purpose of improving resistance to fatigue, stress corrosion cracking, and galling (see 6.1).

2. APPLICABLE DOCUMENTS

2.1 Government documents.

2.1.1 Specifications, standards, and handbooks. The following specifications, standards, and handbooks form a part of this document to the extent specified herein. Unless otherwise specified, the issues of these documents are those listed in the issue of the Department of Defense Index of Specifications and Standards (DODISS) and supplement thereto, cited in the solicitation (see 6.2).

SPECIFICATIONS

FEDERAL

RR-S-366 - Sieves, Test

MILITARY

MIL-S-851 - Steel Grit, Shot, and Cut Wire Shot; and Iron Grit and Shot-Blast Cleaning and Peening
MIL-S-5002 - Surface Treatments and Inorganic Coatings for Metal Surfaces of Weapon Systems
MIL-G-9954 - Glass Beads, For Cleaning and Peening

Beneficial comments (recommendations, additions, deletions) and any pertinent data which may be of use in improving this document should be addressed to: Director, US Army Laboratory Command, Materials Technology Laboratory, ATTN: SLCMT-MEE, Watertown, MA 02172-0001 by using the Standardization Document Improvement Proposal (DD Form 1426) appearing at the end of this document or by letter.

AMSC N/A

AREA MFFP

DISTRIBUTION STATEMENT A Approved for public release; distribution unlimited.

STANDARDS

MILITARY

MIL-STD-45662 - Calibration Systems Requirements

(Unless otherwise indicated, copies of federal and military specifications, standards, and handbooks are available from the Naval Publications and Forms Center, (ATTN: NPODS), 5801 Tabor Avenue, Philadelphia, PA 19120-5099.)

2.2 Non-Government publications. The following documents form a part of this specification to the extent specified herein. Unless otherwise specified, the issues of the documents which are DoD adopted are those listed in the issue of the DODISS cited in the solicitation. Unless otherwise specified, the issues of documents not listed in the DODISS are the issues of the documents cited in the solicitation (see 6.2).

SAE Standards and Recommended Practices

J441 - Cut Wire Shot
J1830 - Ceramic Shot for Peening

(Application for copies should be addressed to SAE, 400 Commonwealth Drive, Warrendale, PA 15096.)

(Non-Government standards and other publications are normally available from the organizations that prepare or distribute the documents. These documents also may be available in or through libraries or other informational services.)

2.3 Order of precedence. In the event of a conflict between the text of this document and the references cited herein, the text of this document takes precedence. Nothing in this document, however, supersedes applicable laws and regulations unless a specific exemption has been obtained.

3. REQUIREMENTS

3.1 Shot.

3.1.1 Material. The shot used shall be made from cast iron, cast steel, cut steel wire (or stainless cut wire), glass, or ceramic as specified or approved. The hardness shall be determined by any of the various methods applicable to small sections at loads determined to provide a reliable conversion to Rockwell C. Steel and iron shot shall conform to MIL-S-851. For steel parts over 200,000 psi tensile strength, use hard steel shot in the range 55-65 HRC or ceramic shot, hardness comparable to 57-63 HRC, unless otherwise specified (see 6.14). Stainless steel cut wire shot, type 302 or 304 (condition B spring temper), and carbon steel cut wire shot shall conform to SAE J441. Glass beads shall conform to MIL-G-9954 except for sieve analysis. Ceramic beads shall meet the requirements of SAE J1830.

3.1.2 Size. Unless otherwise specified, the size of shot charged into the machine, whether new shot, used shot, or reclassified shot, shall be at the option of the contractor and shall be as specified in table II (cast

sizes), table III (cut wire sizes), table IV (glass bead sizes) or table V (ceramic bead sizes).

3.1.3 Shape. The shot or beads shall be free from sharp edges and inspected for deformed shapes or broken shapes when examined per 4.3.1, 4.3.3, and figure 7. Cut wire shot, if used, shall be preused or burnished to eliminate sharp edges (see 6.17.1) A given sample size shall contain no more than the number of unacceptable deformed shapes as shown in figure 7, and defined in table I below (see 3.3.9).

TABLE I. Maximum allowable number of unacceptable deformed shapes

Cast Shot Sizes	Cut Wire Sizes	Glass Bead Sizes (Inches)	Ceramic Bead Sizes (Inches)	Sample Size (Inches)	*Maximum Allowable Number of Unacceptable Deformed Shapes
930	--	.132-.094	--	1 x 1	8
780	--	.111-.079	--	1 x 1	11
660	CW-62	.094-.066	--	1 x 1	16
550	CW-54	.079-.056	--	1 x 1	22
460	CW-47	.066-.047	--	1 x 1	32
390	CW-41	.056-.039	--	1 x 1	45
330	CW-35	.047-.0331	0.046	1/2 x 1/2	16
--	CW-32	--	--	1/2 x 1/2	18
280	CW-28	.039-.0278	--	1/2 x 1/2	23
230	CW-23	.0331-.0234	0.033	1/2 x 1/2	32
190	CW-20	.0278-.0197	--	1/2 x 1/2	45
170	--	.0234-.0165	0.024	1/4 x 1/4	16
130	--	.0197-.0139	--	1/4 x 1/4	23
110	--	.0165-.0117	0.017	1/4 x 1/4	32
70	--	.0139-.0098	--	1/4 x 1/4	45
--	--	.0117-.0083	0.012	1/8 x 1/8	16
--	--	.0098-.0070	--	1/8 x 1/8	22
--	--	.0083-.0059	0.008	1/8 x 1/8	31

*These numbers are approximations based on approximately 10% of the actual particle count in the given sample size.

3.2 Equipment.

3.2.1 Automatic shot peening. The machine used for shot peening shall provide means for propelling shot by air pressure or centrifugal force against the work, and mechanical means for moving the work through the shot stream or moving the shot stream through the work in either translation or rotation, or both, as required. The machine shall be capable of reproducing consistently the shot peening intensities required. Except for wet glass bead peening (see 3.3.9), the equipment shall continuously remove broken or defective shot so that this shot will not be used for peening.

3.2.2 Computer-controlled shot peening. When specified in the contract or purchase order (see 6.2 and 6.8), the machine used for shot peening shall

be as in 3.2.1 and also shall be equipped with computer aided monitoring equipment. This equipment shall continuously monitor critical process parameters through interaction with a sensing system. The media shall be metered to each nozzle and wheel with the desired shot flow. Process parameters shall be as specified by the procuring activity (see 6.9). The machine shall be stopped immediately and corrective action shall be taken when any of the established process limits is violated. The electronic system used for monitoring and controlling shot peening shall include a data recording device which will mark (plot) process interruptions or inconsistencies, and shall be maintained for the purpose of providing a hard copy record.

3.3 Procedure.

3.3.1 Dimensions and condition of parts. Areas of parts to be shot peened shall be within dimensional and surface finish requirements before peening. All heat treatment, machining and grinding shall be completed before shot peening. All fillets shall be formed, all burrs shall be removed, and all sharp edges and corners to be peened shall be provided with sufficient radii to result in complete coverage without any distortion prior to peening (see 6.15).

3.3.2. Precleaning. Except as otherwise specified or permitted, all areas to be peened shall be cleaned in accordance with MIL-S-5002. Procedures for stripping coatings shall be as specified or approved in the contract or on the applicable drawings.

3.3.3 Masking. Areas of the part or work piece and the dimensional tolerances of these areas which are designated in the contract or applicable drawing to be free from any shot peening marks shall be suitably masked or otherwise handled to protect such surfaces from the shot stream or subsequent damage. Areas not requiring peening and not required to be masked shall be considered optional.

3.3.4 Magnetic particle or penetrant inspection. Except as otherwise specified, when magnetic particle or dye penetrant inspection is required, parts shall be subjected to such inspection before peening.

3.3.5 Loading. Unless otherwise specified or permitted, parts shall be free from externally applied loads or forces during shot peening.

3.3.6 Peening intensity. Unless otherwise specified on the drawing or in the contract, the intensity value of the shot stream used on the part shall be as specified in table VI for the thickness of the material being peened. If only a minimum intensity is specified, the variation from the specified minimum intensity shall be - 0, + 30% rounded to the nearest unit, but in no case less than 3 intensity units (A, C, or N) unless otherwise specified. For example, a specified peening intensity of 6A would denote an arc height of 0.006-0.009 inches on the "A" specimen. Shot peening of parts shall be accomplished using the same parameters (time, distance, blast pressure, angle of incidence, etc.) as used on the test strip.

3.3.7 Coverage. Areas of parts shot peened in compliance with design requirements shall be peened to complete visual coverage (see 4.4.1 and 6.11). When a surface on which peening is required is obstructed and it is

impossible to obtain complete visual coverage by direct impact, coverage by reflected shot is allowed. Full coverage will not be required if the part is peened only for forming or straightening. Critical applications shall be as specified by the procuring activity (see 4.2 and 6.11).

3.3.7.1 Boundary variation. Unless otherwise specified, the variation in boundaries of areas to be peened, when limited, shall be -0 to +1/8 inch.

3.3.7.2 Fillets and shielded areas. Unless otherwise specified, the nominal size of shot used on fillet surfaces shall not be greater than one-half the fillet radius. For slots or other apertures, through which shot must pass to peen shielded critical areas, the nominal shot diameter shall not be greater than 1/4 the diameter or width of such aperture.

3.3.8 Minimum shot size for peening materials. Except as otherwise specified or permitted, or in cases such as when shielded areas are involved, materials shall not be peened with shot smaller than the following for the intensities given:

<u>Intensity</u>	<u>Peening Media</u>
.012A	S-280 or CW-28 or GB (.039-.028) or ceramic bead size .033
.016A	S-390 or CW-41 or GB (.056-.039) or ceramic bead size .046
.020A	S-550 or CW-54 or GB (.079-.056)

3.3.9 Shot maintenance. The shot or beads shall be maintained in the machine so that not more than 20% of the particles, by weight, shall pass through the sieve number specified in table VII for the shot size used. Metallic shot shall be checked at least every eight hours of operation to assure that not more than 10% of the shot by actual count is deformed or broken; glass beads shall be checked at least every two hours of operation to assure that not more than 10% of the beads by actual count are deformed or broken (see 3.1.3 and table I). When wet glass peening is used, the entire slurry charge shall be changed at least every two hours for compliance with this requirement. Ceramic beads shall be checked at least every four hours to assure that not more than 5% of the beads by actual count are deformed or broken. In all cases, at least one determination shall be made at the beginning and one at the end of each period of operation or part change.

3.3.10 Post treatments. No manufacturing operations which relieve stresses developed by peening or which develop detrimental residual stresses shall be permitted after shot peening. When peened parts are heated after shot peening as for baking of protective coatings, to relieve hydrogen embrittlement after electroplating, or other thermal treatment, the temperatures employed shall be limited as follows (see 6.13):

<u>Material</u>	<u>Temperature</u>
Steel parts*	475°F maximum
Stainless steel parts**	750°F maximum
Aluminum alloy parts	200°F maximum
Magnesium alloy parts	200°F maximum
Titanium alloy parts	600°F maximum
Nickel alloy parts	1000°F maximum
Cobalt alloy parts	1000°F maximum

*Except 300°F for steel parts that are tempered below the recommended 475°F maximum, after a quench hardening operation.

**Except 475°F for PH steels and cold worked 300 series stainless steels

3.3.10.1 Residual shot removal. After shot peening and removal of protecting masks, all shot and shot fragments shall be removed from surfaces of articles. Only methods which will not erode or scratch surfaces shall be used.

3.3.10.2 Cleaning. Aluminum alloy parts which have been peened with metallic shot shall be chemically cleaned by a preapproved cleaning procedure.

3.3.10.3 Protection from corrosion. Shot peened parts shall be protected from corrosion during processing and until final coating or packaging is completed. The method of protection shall be as specified or approved in the contract or purchase order.

4. QUALITY ASSURANCE PROVISIONS

4.1 Responsibility for inspection. Unless otherwise specified in the contract or purchase order, the contractor is responsible for the performance of all inspection requirements (examinations and tests) as specified herein. Except as otherwise specified in the contract or purchase order, the contractor may use his own or any other facilities suitable for the performance of the inspection requirements specified herein, unless disapproved by the Government. The Government reserves the right to perform any of the inspections set forth in this specification where such inspections are deemed necessary to ensure supplies and services conform to prescribed requirements.

4.1.1 Responsibility for compliance. All items shall meet all requirements of section 3. The inspection set forth in this specification shall become a part of the contractor's overall inspection system or quality program. The absence of any inspection requirements in the specification shall not relieve the contractor of the responsibility of ensuring that all products or supplies submitted to the Government for acceptance comply with all requirements of the contract. Sampling inspection, as part of manufacturing operations, is an acceptable practice to ascertain conformance to requirements, however, this does not authorize submission of known defective material, either indicated or actual, nor does it commit the Government to accept defective material.

4.2 Shot peening intensity. Unless otherwise specified on the drawing or in the contract, the peening intensity value used on the part shall be as specified in table VI for the material thickness involved; and peening intensities shall be monitored at all locations specified by the procuring activity in accordance with 4.2.4 (see 6.5).

4.2.1 Sampling. At least one intensity determination shall be made to represent each machine for each two hours of continuous operation or fraction thereof where glass beads are used, for each four hours of continuous operation or fraction thereof where ceramic beads are used, and for each eight hours of continuous operation or fraction thereof where cast steel, cast iron,

or cut steel wire (or stainless cut wire) shot is used. In all cases, at least one determination shall be made at the beginning and one at the end of each period of operation or part change.

4.2.2 Test strip specimens. A test strip specimen is an Almen test strip used to measure "intensity." At least two test strip specimens conforming in dimensions and mechanical properties to figures 1, 2 or 3 shall be used for each intensity determination at each location.

4.2.3 Saturation curve. For initial process development, a saturation curve shall be generated for each location where intensity is to be verified. A curve is produced by exposing individual test strips for increasing time periods and plotting the results (exposure time vs. arc height). A minimum of four points other than zero shall be used to define the curve; one of the four points used to indicate saturation shall be at least double the time of the saturation point. Saturation is achieved when, as the exposure time for the test strips is doubled, the arc height does not increase by more than 10% (see figure 8 and 6.12). The arc height at saturation for each location must be within the required arc height range for that location. The reuse of test strips is not permitted.

4.2.4 Test procedure. The test strip specimens selected in accordance with 4.2.1 shall be attached as shown in figure 5, to holders of the form and dimensions shown in figure 4, and mounted on a fixture or article and exposed to the shot stream in a manner which simulates conditions used for the articles. The test strips shall be run for the saturation time established by the saturation curve (see 4.2.3). After exposure the test strips shall be removed from the holders and the amount of deflection measured with a micrometer gage, of the form and dimensions shown in figure 6. The arc height or amount of deflection measured on the test strips shall be within the specified intensity range (see 3.3.6). If the arc height measured is not within the intensity range specified, the process parameters must be adjusted and new saturation curves must be run (see 4.2.3). In using the micrometer gage, the central portion of the unpeened side of the test strip shall be placed against the indicator stem of the gage. A peened test strip shall not be re-peened after being removed from the test strip holder.

4.2.5 Test records. Test strip specimens and test records shall accompany peened parts, and shall be inspected along with the appropriate lot. The following information shall be recorded for each specimen:

- (a) Lot number and other production control numbers
- (b) Part number
- (c) Number of parts in lot
- (d) Date peened
- (e) Shot peening machine used and machine settings
- (f) Specified peening intensity and actual peening intensity by test strip identification numbers if test fixture requires use of more than one strip
- (g) Shot size, type, hardness, standoff (distance), length of time of exposure to shot stream, and shot flow rate (see 6.17.6)
- (h) Percent coverage
- (i) Shot velocity or air pressure

MIL-S-13165C

4.2.6 Computer-controlled shot peening. When auxiliary computer controlled equipment is used, calibration of the monitoring systems shall be in accordance with MIL-STD-45662. Intensity verification as per 4.2.4 shall be done prior to initial operation and after any calibration.

4.3 Shot size and uniformity.

4.3.1 Sampling. Sampling for shot size and uniformity shall be at the frequencies specified in 4.2.1 for intensity. Where cut wire shot is used, it shall be inspected for absence of sharp edges and roundness (see 3.1.3).

4.3.2 Test procedure. Tests for shot size and uniformity for compliance with the requirements of 3.1 shall be made using sieves conforming to Federal Specification RR-S-366.

4.3.3 Visual examination (sample size). Samples of shot for visual examination shall consist of the number of shot in one layer which completely fills an area of 1, 1/2, 1/4, or 1/8 inch square as applicable (see table I). If feasible a minimum of 100 beads or pieces of shot shall constitute a single sample (see 6.16). Acceptable and unacceptable shapes are shown in figure 7.

4.4 Inspection of shot peened articles.

4.4.1 Coverage. Unless otherwise specified articles shall be 100% visually inspected for compliance with the coverage requirements of 3.3.7 using either method described in 6.11a or 6.11b.

4.4.2 Corrosion protection. Articles shall be inspected for compliance with the method of protection specified in the contract or purchase order.

5. PACKAGING

This section is not applicable to this specification.

6. NOTES

(This section contains information of a general or explanatory nature that may be helpful, but is not mandatory.)

6.1 Intended use. Shot peening is intended to induce surface compressive stresses in metal parts which are subjected to repeated applications of complex load patterns such as axles, springs (helical, torsional and leaf), gears, shafting, aircraft landing gear, structural parts, etc., for the purpose of improving resistance to fatigue and stress corrosion cracking. Ceramic and glass bead peening, either wet or dry, is used when iron contamination of non-ferrous parts is a consideration.

6.2 Acquisition requirements. The following will be as specified or approved in the contract or in the applicable drawings:

- (a) Title, number, and date of this specification
- (b) Issue of DODISS to be cited in the solicitation, and if required, the specific issue of individual documents referenced (see 2.1.1 and 2.2)

- (c) The type of shot to be used (see 3.1.1)
- (d) Shot size (and hardness if cast steel shot is to be used), if particular size required (see 3.1.2 , 3.3.7.2, 3.3.8 and 6.7)
- (e) Type of equipment to be used - automatic or computer controlled (see 3.2.1 and 3.2.2)
- (f) Methods for cleaning surfaces and methods for stripping coatings, if applicable (see 3.3.2)
- (g) Designation of locations to be peened (including intensity verification areas), or locations to be free from peening as applicable (see 3.3.3)
- (h) If magnetic particle or dye penetrant inspection is required on peened parts (see 3.3.4)
- (i) If externally applied forces are permissible during peening (see 3.3.5)
- (j) Intensity requirements if other than 3.3.6
- (k) Over performance peening coverage when required to insure 100% coverage for performance on critical applications (see 3.3.7)
- (l) Method of coverage verification (see 3.3.7 and 6.11)
- (m) Shot size limitations in obstructed areas, boundaries, and other peening operations (see 3.3.8)
- (n) Specific cleaning formulation(s) or approved cleaning procedure for peened parts, if applicable (see 3.3.10.2)
- (o) Method of protecting shot peened parts from corrosion (see 3.3.10.3)

6.3 Effective peening. Shot peening, to have the desired effect, requires that the specified intensity and coverage be achieved on critical areas (see 6.17.3), where high tensile stresses or stress ranges are most likely to cause fatigue or stress corrosion failures in service.

6.4 Special peening procedure. Where a special procedure is required, applicable drawings or a contract will designate such critical areas (see 4.2).

6.5 Additional peening. Shielded or partially shielded areas, walls of deep recesses, or other areas less accessible to the maximum effect of the blast stream will receive less peening as to intensity and coverage than more exposed or more favorably oriented areas, and may therefore require additional peening or repositioning of the part to achieve correct peening in these areas. Use of special nozzle equipment or employment of deflector peening operations may be useful in diminishing the amount of additional peening.

6.6 Peening thin sections. The peening of very thin or small sections to high intensities should be avoided because of the distortion and high residual tensile stresses in the core material that may result from such peening.

6.7 Shot size selection. In selecting shot sizes, consideration should be given to the following factors:

- (a) Shape of parts
- (b) Size of fillets (small shot to get into small fillets, etc.) (see 3.3.7.2)
- (c) Intensity desired (the size of shot limits the intensity which can be obtained in a given peening machine). Therefore, it may be necessary to use a larger shot to obtain a higher intensity or to reduce intensity requirements when shot must be small for consideration (b)
- (d) Finish (at equal intensities larger shot will produce a finer surface finish)
- (e) Whether or not to use small shot at high intensity on aluminum or magnesium alloy parts

6.8 Computer-controlled shot peening selection. Computer-controlled shot peening equipment should be considered for use in the following instances:

- (a) Man flight vehicle components
- (b) Components where shot peening is used as part of the design strength of the component
- (c) Components which are considered critical to system success

6.9 Process parameters. Parameters which may affect the shot peening process include, but are not limited to, the following:

- (a) Shot flow rate
- (b) Air pressure or wheel speed (RPM)
- (c) Impact angle
- (d) Distance of nozzle(s) or wheel(s) from workpiece
- (e) Relative motion between workpiece and nozzle(s) or wheel(s)

Shot peening procedures should be as agreed upon between the contractor and the procuring activity and will comply with the process parameters established in 3.2.2 and 3.3.

6.10 Intensity comparisons. For comparisons of the nominal intensity designations, type C test specimen deflection may be multiplied by 3.5 to obtain the approximate deflection of a type A test strip. Test strip "A" is ordinarily used for arc heights up to 0.024 inches; for higher intensity peening, test strip C is used. For intensities below .004A the type "N" test strip should be used. For comparison of the nominal intensity designations, type "A" test strip deflection may be multiplied by three to obtain the approximate deflection of a type "N" test strip (see figures 1, 2 and 3).

6.11 Coverage. Complete visual coverage is defined as a uniform and complete denting or obliterating of the original surface of the part or work piece as determined by either of the following methods:

(a) Visual examination using a ten power magnifying glass.

(b) Visual examination using a ten power magnifying glass in conjunction with an additional visual examination using an approved liquid tracer system (see 6.17.4) may be used for process control by the contractor. Unless otherwise specified, the procedure for using an approved liquid tracer system is described as follows:

Prepare a control specimen of the actual work piece. Coat this control specimen with tracer liquid by dipping, spraying, or painting and allow the liquid to dry. Check the specimen under a light (an ultraviolet light is used for a fluorescent tracer system) to insure that complete coating of the area to be shot peened has been accomplished. This control specimen is shot peened using the correct intensity and parameters specified for complete coverage and is then re-examined under the light (or ultraviolet light) in order to determine if the tracer residue has been completely removed. Full coverage is indicated by complete removal of the tracer residue. Coverage of actual production pieces can be established by using the same procedure used for control specimens. This can be done by utilizing the liquid tracer for each part or on a statistical sampling basis.

NOTE: The liquid tracer system must be approved by the procuring activity. Data, showing that 100% coverage of the part is obtainable by using this tracer system, is required.

6.12 Intensity. Intensity can only be established by plotting a saturation curve, as shown in figure 8, and assuring that the required intensity (determined by the arc height of the test strip) falls on the right side of the knee of the curve. By doubling the time of exposure, the arc height of a test strip should not increase by more than 10%. - *Don't mean the height*

6.13 Process temperatures. Processing or service temperatures of shot peened parts shall be limited to the temperatures in 3.3.10 unless test data for specific applications support the satisfactory use of higher temperatures.

NOTE: Operations performed after shot peening such as auxilliary electrodeposited coatings may cause tensile stresses on the steel surface. Procedures for relieving these stresses will be specified in the contract, or part drawing, or will be in accordance with the applicable specification.

6.14 Multiple exposure times. Although test strips peened to saturation generally exhibit complete (100%) visual coverage, additional factors may need to be built into the contractor's process or procedure which will insure that minimum coverage has been specified for the peening of steels over 200,000 psi tensile strength and/or for critical applications when over performance peening is required to insure complete coverage (see 3.3.7). Unless otherwise specified the factors required to achieve 100% coverage is the responsibility of the contractor.

MIL-S-13165C

6.15 Condition of material before peening. For informational purposes, MIL-P-81985, the military specification for peening of metals, discusses the condition of material prior to peening.

6.16 Examination of shot sample. It may be necessary to use a lighted binocular microscope to inspect the smaller shot for size and uniformity (see 4.3.3).

6.17 Definitions.

6.17.1 Burnishing. Burnishing is the smoothing of surfaces by rubbing or tumbling, accomplished chiefly by the movement rather than the removal of the surface layer.

6.17.2 Contractor. An individual or organization outside the U. S. Government which has accepted any type of agreement or order for providing research, supplies, or services to a U. S. Government Agency.

6.17.3 Critical. The term critical, as in critical areas, is where a failure of any portion would cause loss of system, loss of major component, or loss of personnel.

6.17.4 Liquid tracer system. A tracer system that employs liquid coating material which removes at a rate proportioned to peening coverage. A fluorescent tracer system has, in addition, a pigment which fluoresces under ultraviolet light.

6.17.5 Procuring activity. The term procuring activity is that activity of the Government which actually initiates the request for procurement and maintains the records of the procurement.

6.17.6 Standoff. Standoff is the distance from the shot nozzle to the surface being peened.

6.18 Subject term (key word) listing.

Almen test strip	Saturation curve
Fluorescent Tracer System	Shot peening
Liquid Tracer System	Shot size
Peening intensity	

Custodians:

Army - MR
Navy - AS
Air Force - 11

Preparing activity:

Army - MR

(Project MFFP-0288)

Review activities:

Army - MI, EA, AR, AV, AT
Navy - SH
Air Force - 84, 18

User activities:

Army - AT, ME
Navy - OS
Air Force - 99

(KBWP# ID-0530A/DISK 0117A. FOR MTL USE ONLY)

MIL-S-13165C

TABLE II. Cast shot numbers and screening tolerances.

Peening Shot	All pass U.S. sieve Number and opening 1/	Max 2% on U.S. sieve Number and opening 1/	Max. 50% on U.S. sieve Number and opening 1/	Cumulative min. 90% on U.S. sieve Number and opening 1/	Cumulative min. 98% on U.S. sieve Number and opening 1/
930	5 (.157)	6 (.132)	7 (.11)	8 (.0937)	10 (.0787)
780	6 (.132)	7 (.11)	8 (.0937)	10 (.0787)	12 (.0661)
660	7 (.11)	8 (.0937)	10 (.0787)	12 (.0661)	14 (.0555)
550	8 (.0937)	10 (.0787)	12 (.0661)	14 (.0555)	16 (.0469)
460	10 (.0787)	12 (.0661)	14 (.0555)	16 (.0469)	18 (.0394)
390	12 (.0661)	14 (.0555)	16 (.0469)	18 (.0394)	20 (.0331)
330	14 (.0555)	16 (.0469)	18 (.0394)	20 (.0331)	25 (.0278)
280	16 (.0469)	18 (.0394)	20 (.0331)	25 (.0278)	30 (.0234)
230	18 (.0394)	20 (.0331)	25 (.0278)	30 (.0234)	35 (.0197)
190	20 (.0331)	25 (.0278)	30 (.0234)	35 (.0197)	40 (.0165)
170	25 (.0278)	30 (.0234)	35 (.0197)	40 (.0165)	45 (.0139)
130	30 (.0234)	35 (.0197)	40 (.0165)	45 (.0139)	50 (.0117)
110	35 (.0197)	40 (.0165)	45 (.0139)	50 (.0117)	80 (.0070)
70	40 (.0165)	45 (.0139)	50 (.0117)	80 (.0070)	120 (.0049)

1/ Sieve numbers specified in RR-S-366, number in parenthesis represents sieve opening size (inches).

TABLE III. Cut wire shot (steel/stainless) size classification.

Shot No.	Wire diameter, inches	Weight of fifty pieces grams _{1/}	Length of ten pieces inches _{2/}
CW-62	.062 \pm .002	1.09 to 1.33	.620 \pm .040
CW-54	.054 \pm .002	0.72 to 0.88	.540 \pm .040
CW-47	.047 \pm .002	0.48 to 0.58	.470 \pm .040
CW-41	.041 \pm .002	0.31 to 0.39	.410 \pm .040
CW-35	.035 \pm .001	0.20 to 0.24	.350 \pm .030
CW-32	.032 \pm .001	0.14 to 0.18	.320 \pm .030
CW-28	.028 \pm .001	0.10 to 0.12	.280 \pm .030
CW-23	.023 \pm .001	0.05 to 0.07	.230 \pm .020
CW-20	.020 \pm .001	0.04 to 0.05	.200 \pm .020

1/ Fifty randomly selected particles shall be weighed. The total weight of the fifty pieces shall be within the limits specified in table III above.

2/ Ten randomly sampled shot particles shall be checked for length. All ten pieces selected for this test shall fall within the tolerance shown in table III above.

TABLE IV. Glass bead sizes.

Nominal glass bead size (inches)		Min 99% shall pass sieve number 1/	Min 95% shall pass sieve number 1/	Max 10% shall pass sieve number 1/	Max 5% shall pass sieve number 1/
Max	Min				
.132	.094	5	6	8	10
.111	.079	6	7	10	12
.094	.066	7	8	12	14
.079	.056	8	10	14	16
.066	.047	10	12	16	18
.056	.039	12	14	18	20
.047	.0331	14	16	20	30
.039	.0278	16	18	25	40
.0331	.0234	18	20	30	45
.0278	.0197	20	25	35	50
.0234	.0165	25	30	40	60
.0197	.0139	30	35	45	70
.0165	.0117	35	40	50	70
.0139	.0098	40	45	60	80
.0117	.0083	45	50	70	100
.0098	.0070	50	60	80	120
.0083	.0059	60	70	100	140
.0070	.0049	70	80	120	170
.0059	.0041	80	100	140	200
.0049	.0035	100	120	170	230
.0041	.0029	120	140	200	270
.0035	.0024	140	170	230	325
.0029	.0021	170	200	270	400
.0024	.0021	200	230	325	400

1/ Sieve numbers specified in RR-S-366.

TABLE V. Ceramic bead sizes.

NOMINAL SIZES (inches)	SIEVE NUMBER AND SIEVE OPENING SIZE (in inches) ^{1/}			
	Max 0.5% Retains	Max 5% Retains	Max 10% Pass	Max 3% Pass
0.046	14(.0555)	16(.0469)	20(.0331)	25(.0278)
0.033	18(.0394)	20(.0331)	30(.0234)	40(.0165)
0.024	25(.0278)	30(.0234)	40(.0165)	50(.0117)
0.017	35(.0197)	40(.0165)	50(.0117)	60(.0098)
0.012	45(.0139)	50(.0117)	70(.0083)	80(.0070)
0.008	60(.0098)	70(.0083)	100(.0059)	120(.0049)

1/ Sieve numbers specified in RR-S-366.

TABLE VI. Shot peening intensity.

Material 1/	Steel under 200,000 psi	Steel over 200,000 psi 4/ Titanium and Titanium alloys	Aluminum alloys (metallic shot/ ceramic shot) 5/	Aluminum alloys (non metallic shot)
Under .090 inch thickness	-	-	-	.004 to .008 N
.090 to .375 inch thickness	.008 to .012 A 2/	.006 to .010 A	.006 to .010 A	.008 to .012 N
Over .375 inch thickness	.012 to .016 A 3/	.006 to .010 A	.010 to .014 A	.012 to .016 N

1/ Magnesium alloys response to shot peening is different from the response of other materials. It is essential to avoid broken or deformed peening material. Peening must be done with materials and under conditions which do not induce cracks.

2/ The suffix letter A indicates that the values have been determined by the use of test strip A (see figure 1).

3/ Test strip A is used for arc heights up to 0.024 inches. For greater peening intensity test strip C should be used. Test strip N is used if the intensity is less than .004 inches on the A strip (see figures 2 and 3).

4/ For steel over 200,000 psi, use hard shot or ceramic shot (see 3.1.1). Peening intensity shall be as specified in the contract or drawing.

5/ If steel shot is used, the areas peened should be chemically decontaminated to remove residual iron left on the part. If ceramic shot is used for these intensities no decontamination is required since the shot for the specified material thickness is non-metallic.

TABLE VII. Uniformity of shot to be maintained in machine.

Cast shot sizes	Cut wire sizes	Glass bead sizes, max (inches)	Ceramic bead sizes (inches)	Maximum 20% Passing U.S. sieve Number and opening <u>1/</u>
930	-	.132	-	8(.0937)
780	-	.111	-	10(.0787)
660	-	.094	-	12(.0661)
550	CW-62	.079	-	14(.0555)
460	CW-54	.066	-	16(.0469)
390	CW-47	.056	-	18(.0394)
330	CW-41	.047	0.046	20(.0331)
-	CW-35	-	-	20(.0331)
280	CW-32	.039	-	25(.0278)
230	CW-28	.0331	0.033	30(.0234)
190	CW-23	.0278	-	35(.0197)
170	CW-20	.0234	0.024	40(.0165)
130	-	.0197	-	45(.0139)
110	-	.0165	0.017	50(.0117)
70	-	.0139	-	60(.0098)
-	-	.0117	0.012	70(.0083)
-	-	.0098	-	80(.0070)
-	-	.0083	0.008	100(.0059)
-	-	.0070	-	120(.0049)

1/ Sieve numbers specified in RR-S-366, number in parenthesis represents sieve opening size (inches).

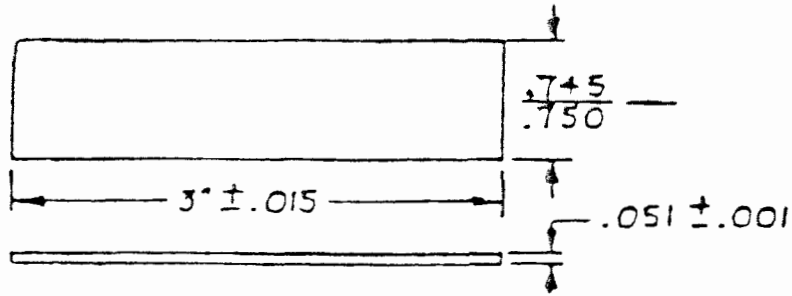

FIGURE 1. Test strip A. $\frac{1}{1}$

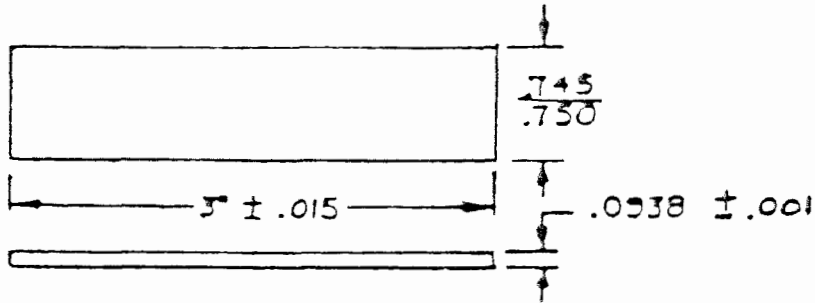

FIGURE 2. Test Strip C. $\frac{1}{1}$

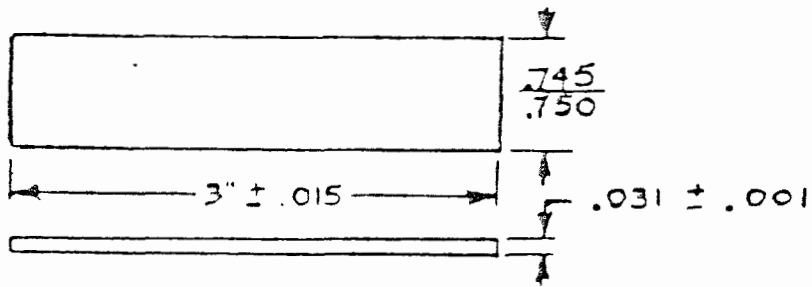

FIGURE 3. Test strip N. $\frac{1}{1}$

$\frac{1}{1}$ Test strip specifications.

- Analysis of stock - SAE 1070
- Cold rolled spring steel
- Square edge number one (on 3" edge)
- Finish-blue temper (or bright)
- Uniformly hardened and tempered to 44-50 HRC
- Flatness - $\pm .0015''$ arc height as measured on gauge shown in figure 6.

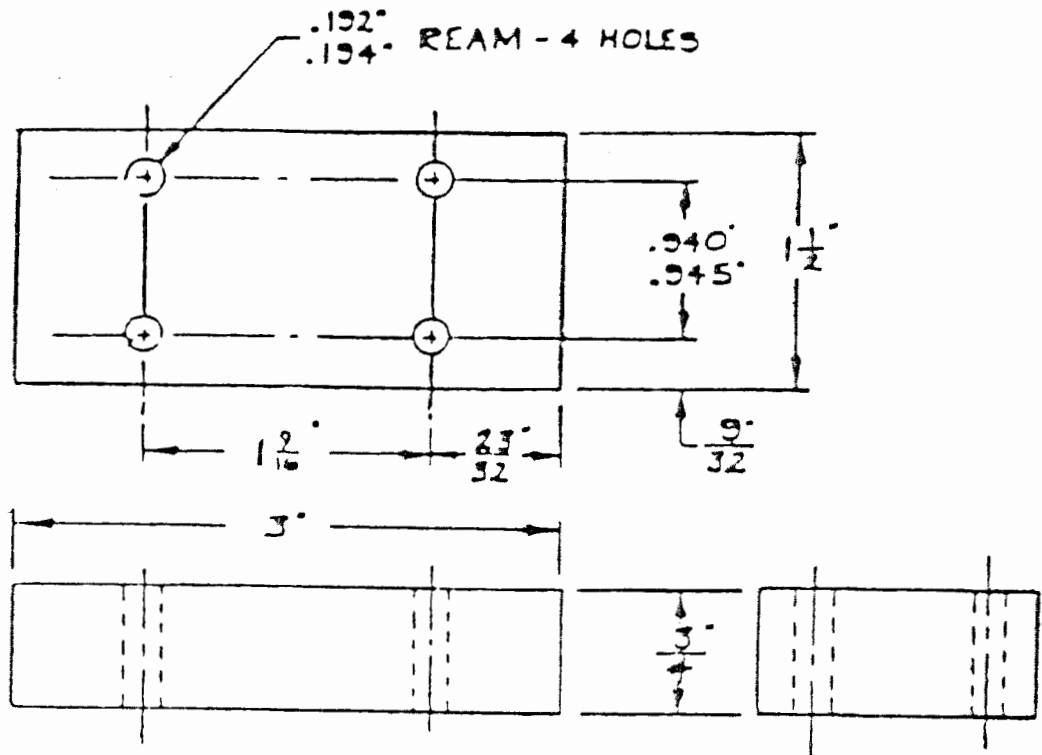

FIGURE 4. Holding fixture.

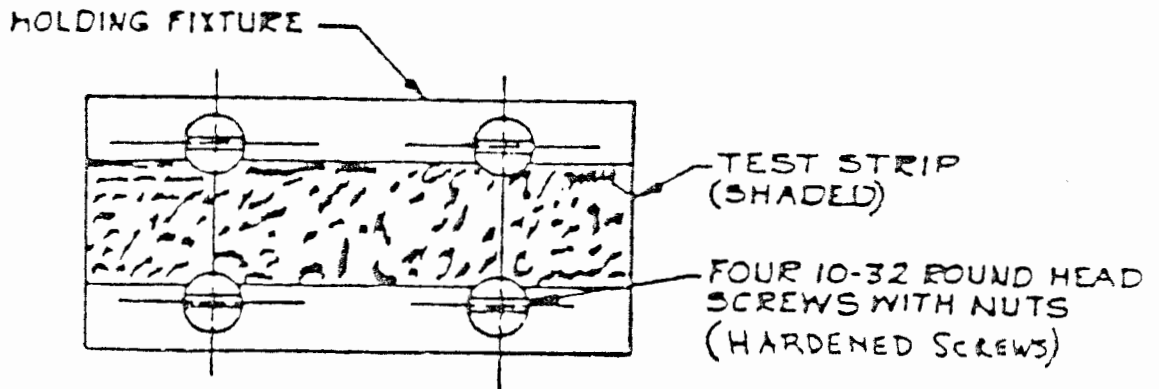

FIGURE 5. Assembled test strip and holding fixture.

DUAL INDICATOR, MAX. VALUE OF GRADUATION
 .001 - COUNTER-CLOCKWISE BACK ADJUSTABLE
 BRACKET, LOW FRICTION JEWELLED BEARINGS,
 EQUIPPED WITH EXTENSION POINT.

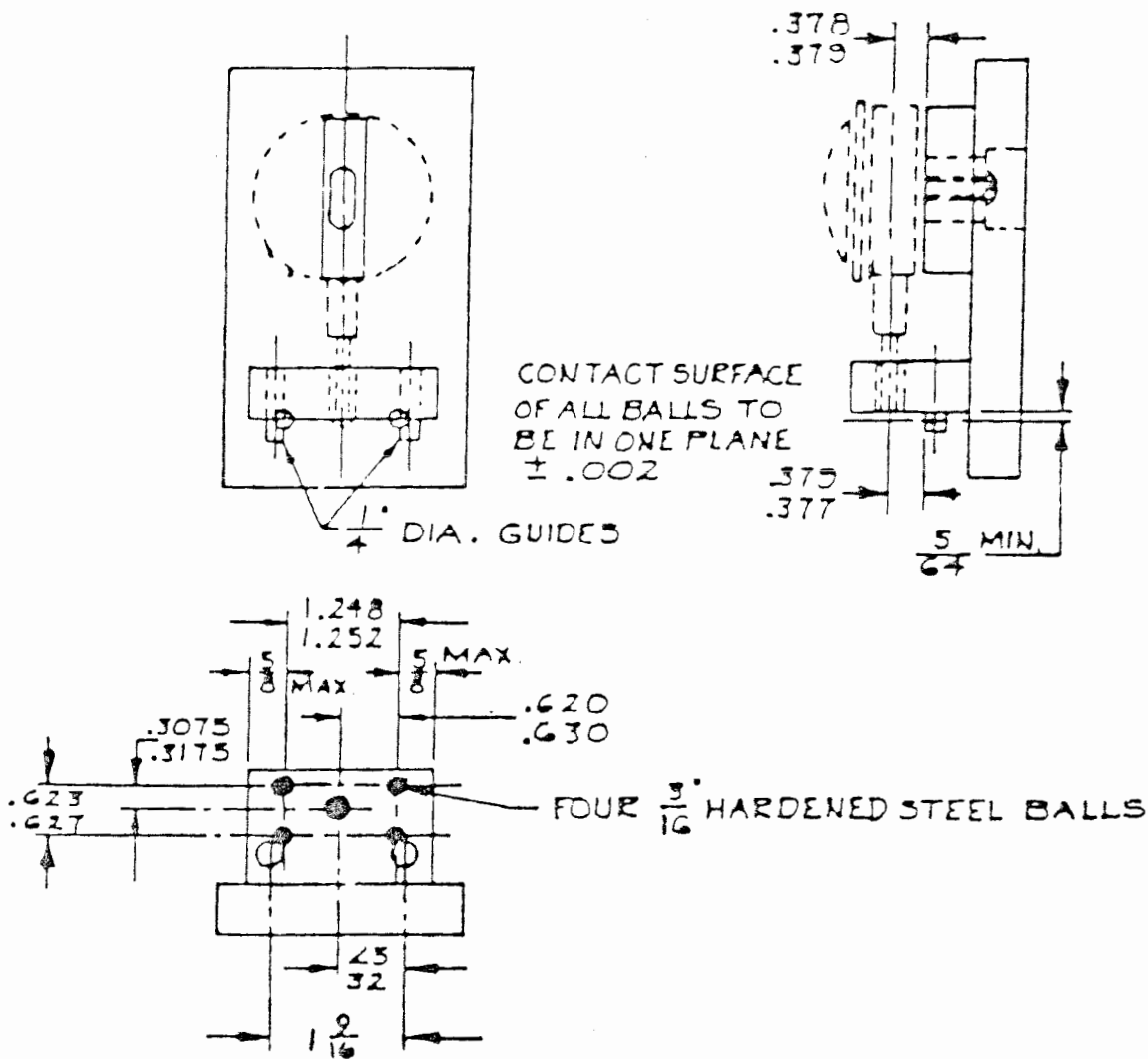

FIGURE 6. Test gauge.

1. Acceptable shapes



2. Unacceptable "deformed" shapes



3. Unacceptable "broken" shapes



FIGURE 7. Shapes (see table I).

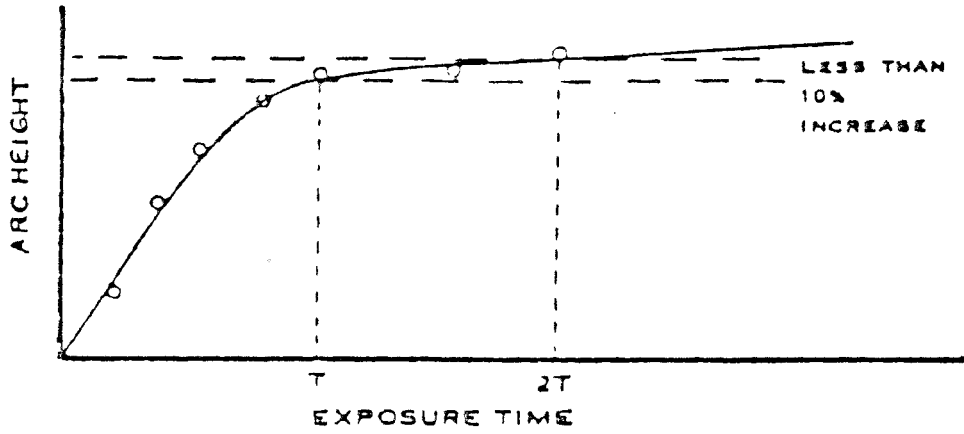

SATURATION CURVE

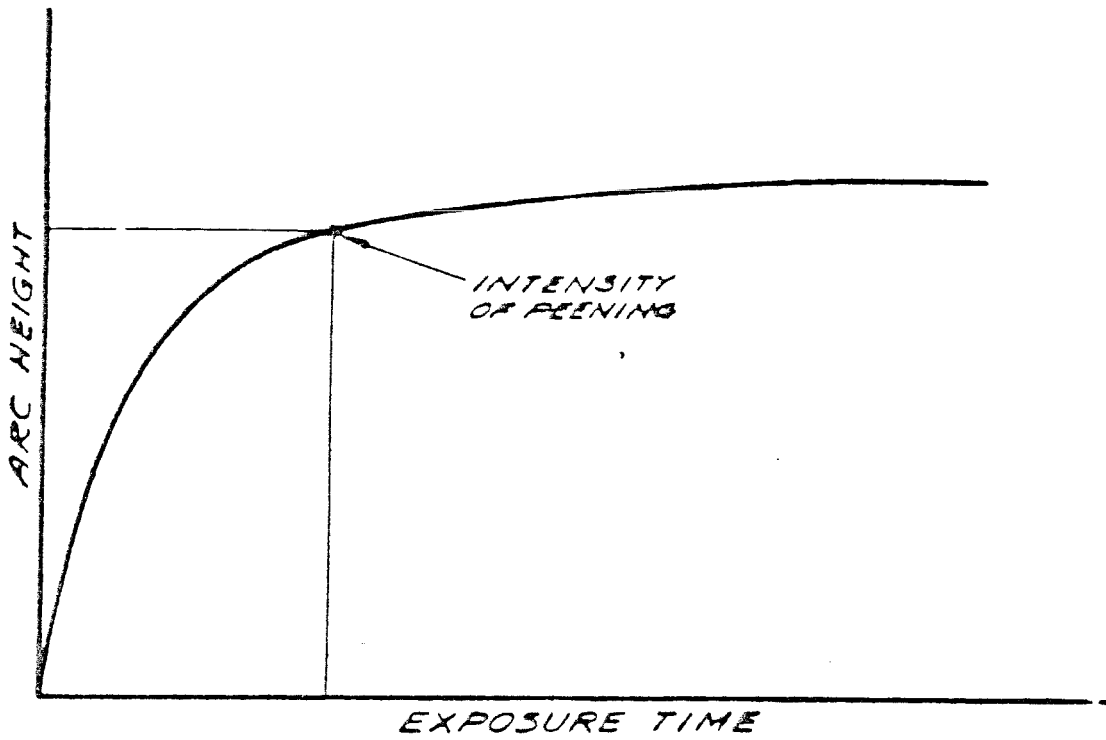

INTENSITY DETERMINATION CURVE

FIGURE 8. Curves.

STANDARDIZATION DOCUMENT IMPROVEMENT PROPOSAL

(See Instructions - Reverse Side)

1. DOCUMENT NUMBER

2. DOCUMENT TITLE

3a. NAME OF SUBMITTING ORGANIZATION

4. TYPE OF ORGANIZATION (Mark one)

VENDOR

USER

MANUFACTURER

OTHER (Specify): _____

b. ADDRESS (Street, City, State, ZIP Code)

5. PROBLEM AREAS

a. Paragraph Number and Wording:

b. Recommended Wording:

c. Reason/Rationale for Recommendation:

6. REMARKS

7a. NAME OF SUBMITTER (Last, First, MI) - Optional

b. WORK TELEPHONE NUMBER (Include Area Code) - Optional

c. MAILING ADDRESS (Street, City, State, ZIP Code) - Optional

8. DATE OF SUBMISSION (YYMMDD)

(TO DETACH THIS FORM, CUT ALONG THIS LINE.)

INSTRUCTIONS: In a continuing effort to make our standardization documents better, the DoD provides this form for use in submitting comments and suggestions for improvements. All users of military standardization documents are invited to provide suggestions. This form may be detached, folded along the lines indicated, taped along the loose edge (*DO NOT STAPLE*), and mailed. In block 5, be as specific as possible about particular problem areas such as wording which required interpretation, was too rigid, restrictive, loose, ambiguous, or was incompatible, and give proposed wording changes which would alleviate the problems. Enter in block 6 any remarks not related to a specific paragraph of the document. If block 7 is filled out, an acknowledgement will be mailed to you within 30 days to let you know that your comments were received and are being considered.

NOTE: This form may not be used to request copies of documents, nor to request waivers, deviations, or clarification of specification requirements on current contracts. Comments submitted on this form do not constitute or imply authorization to waive any portion of the referenced document(s) or to amend contractual requirements.

(Fold along this line)

(Fold along this line)

DEPARTMENT OF THE NAVY



NO POSTAGE
NECESSARY
IF MAILED
IN THE
UNITED STATES

OFFICIAL BUSINESS
PENALTY FOR PRIVATE USE \$300

BUSINESS REPLY MAIL

FIRST CLASS PERMIT NO. 12503 WASHINGTON D. C.

POSTAGE WILL BE PAID BY THE DEPARTMENT OF THE NAVY

Director
US Army Laboratory Command
Materials Technology Laboratory
ATTN: SLCMT-MEE
Watertown, MA 02172-0001

