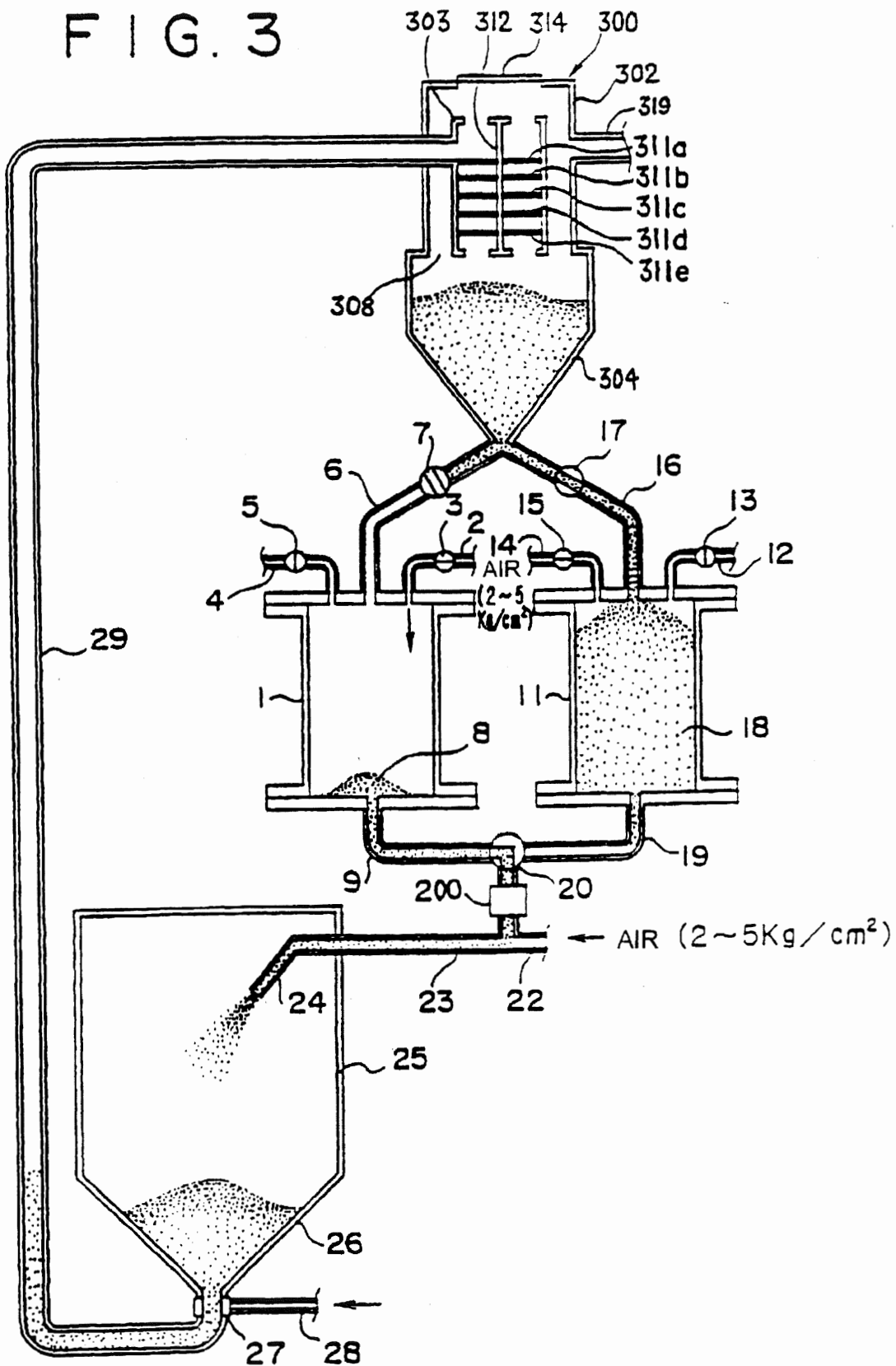





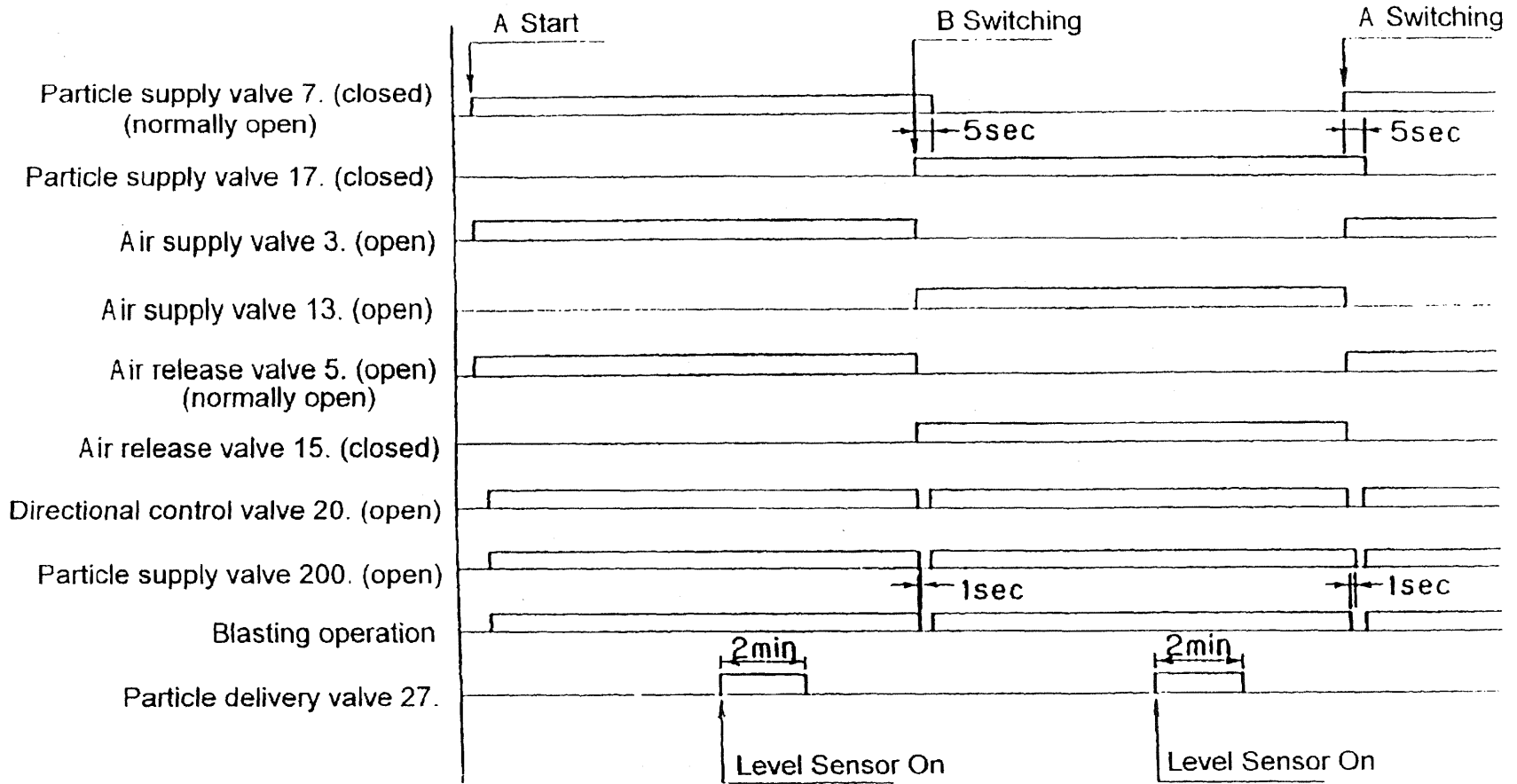

FIG. 3





# FIG. 5



# FIG. 6

(Prior Art)

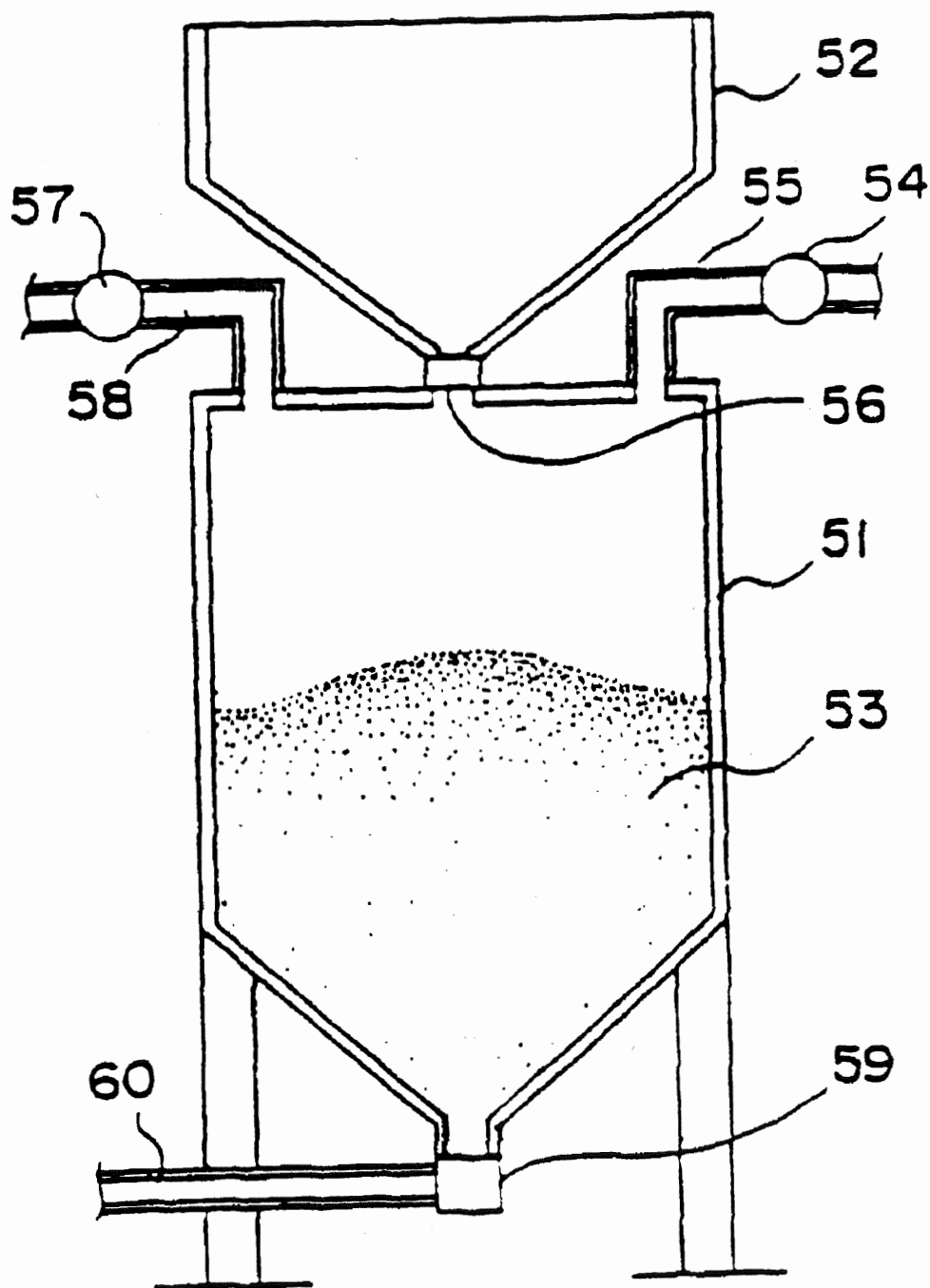

# FIG. 7

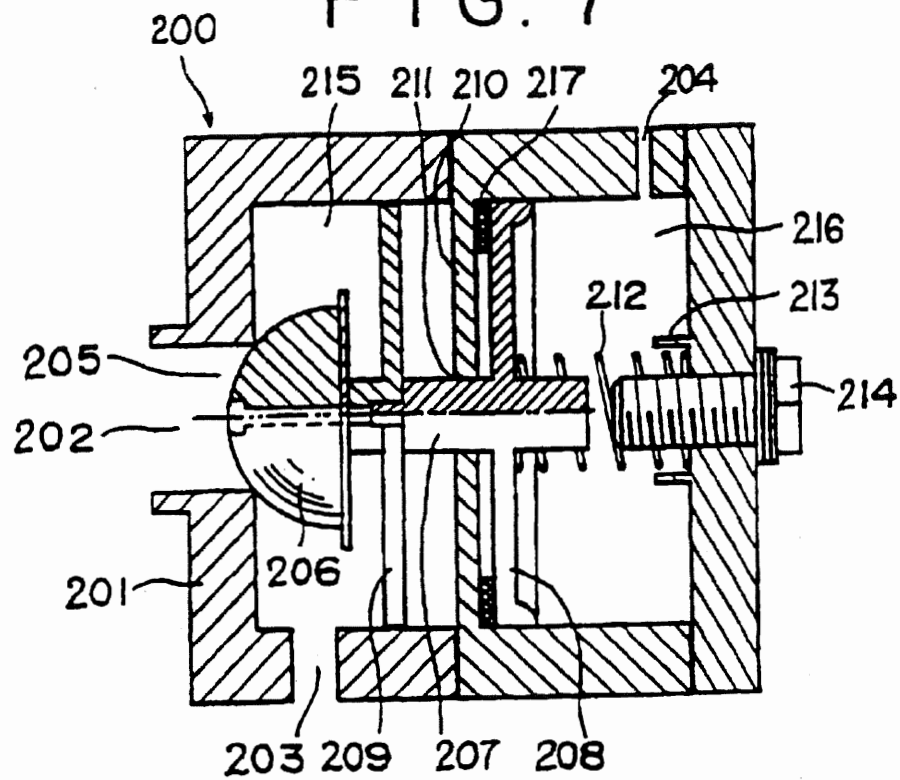

# FIG. 8

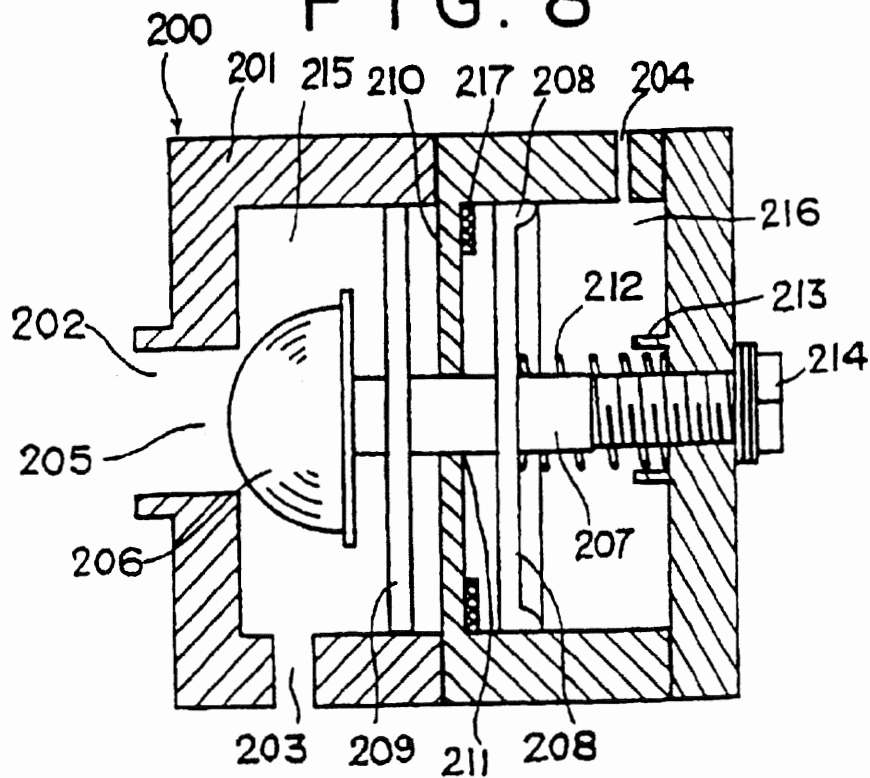
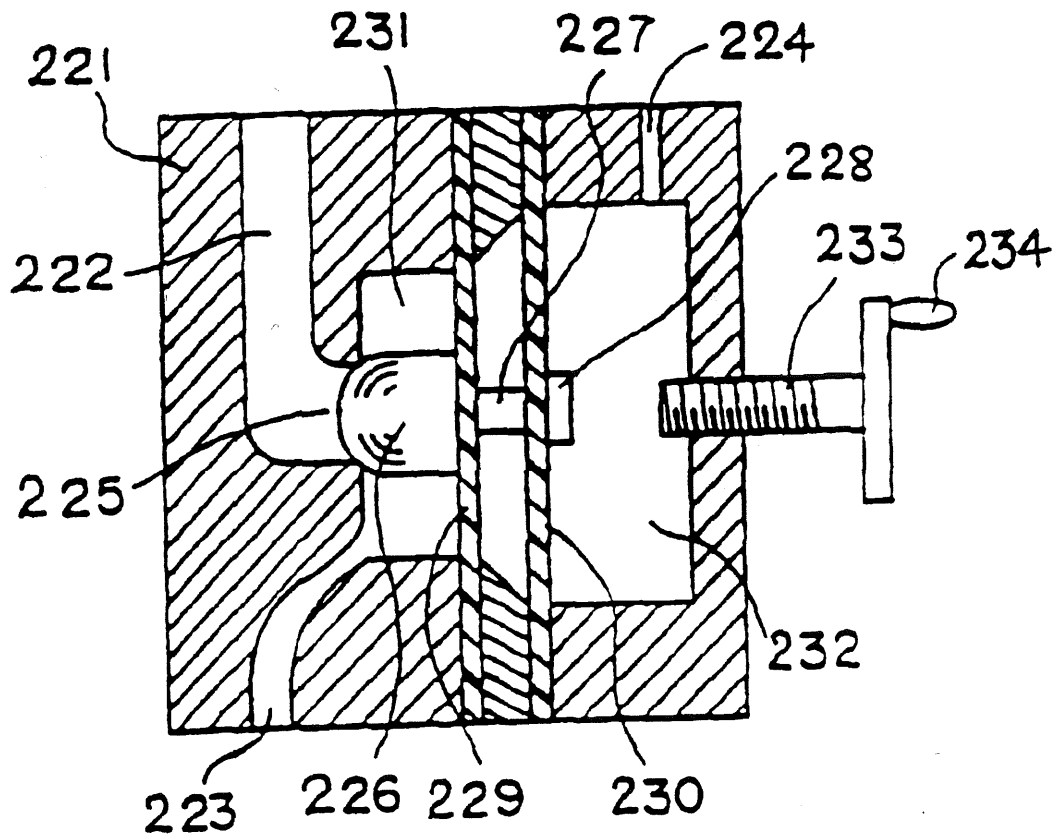
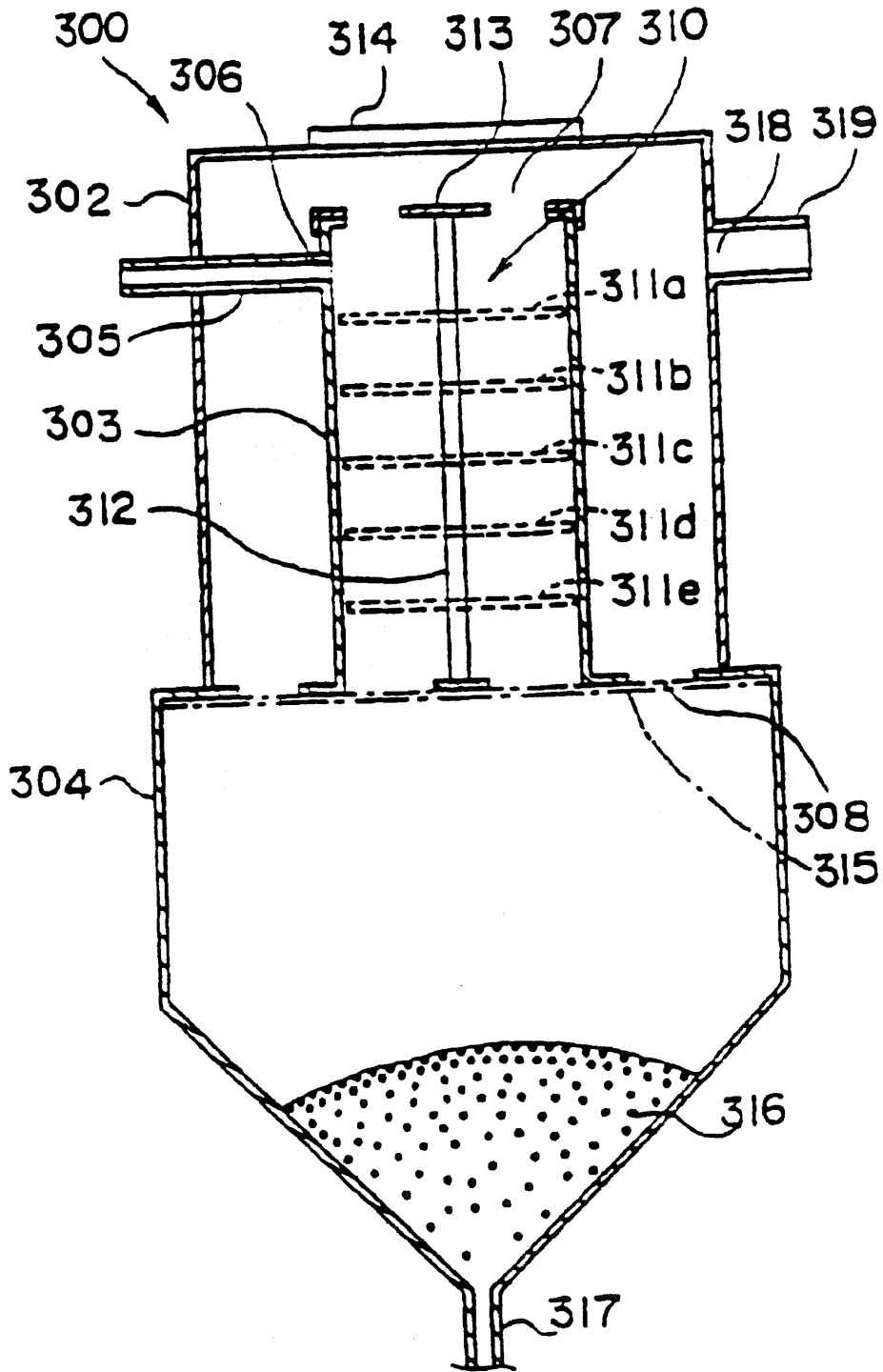



FIG. 9  
(Prior Art)



# FIG. 10



# FIG. 11

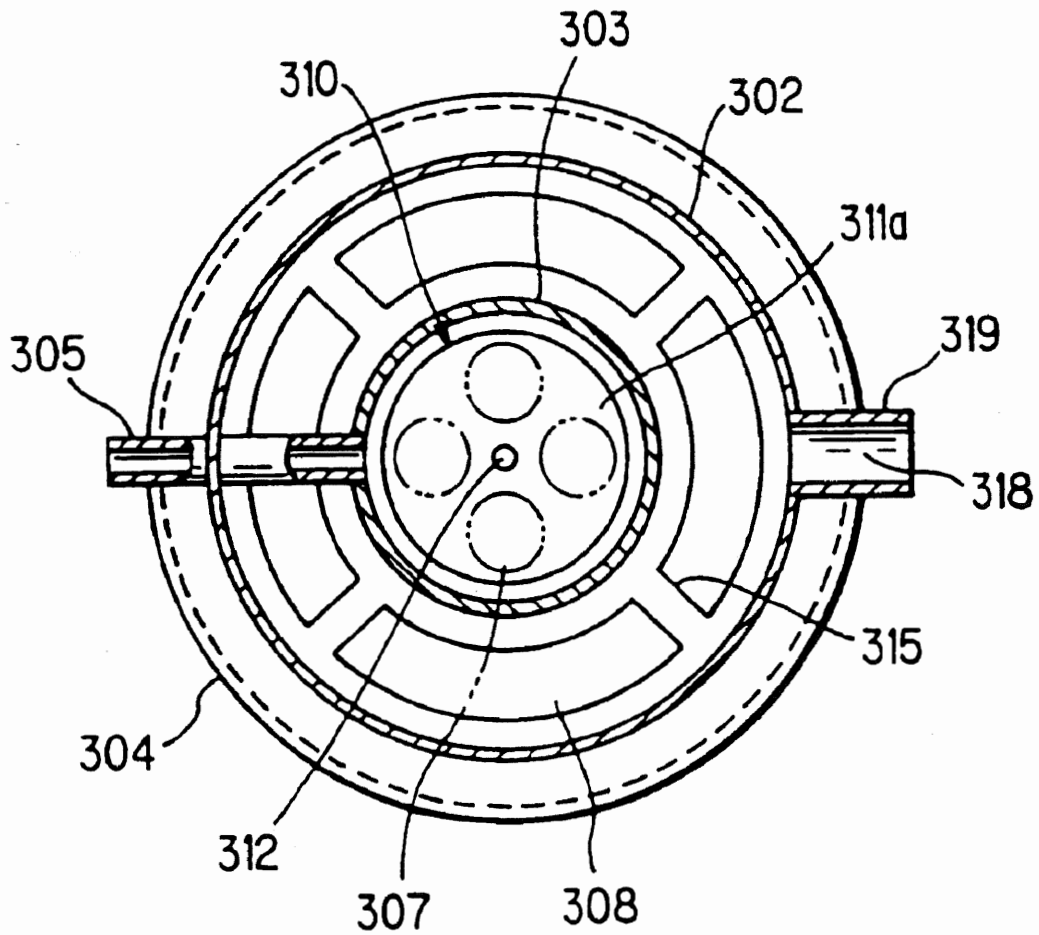

FIG. 12

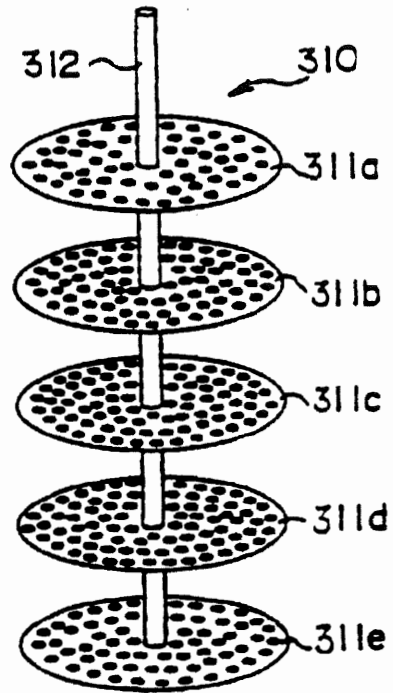

FIG. 13

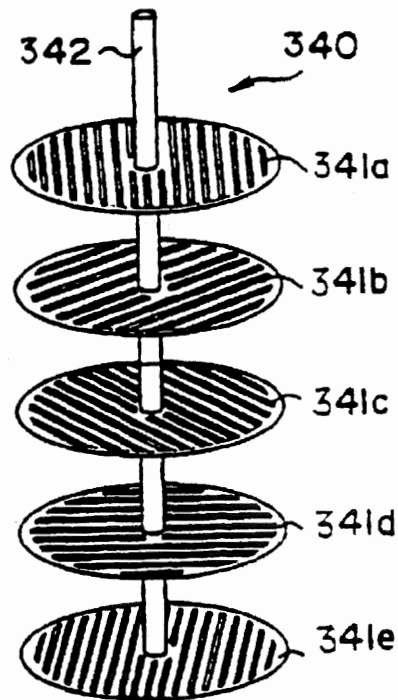

FIG. 14  
(Prior Art)

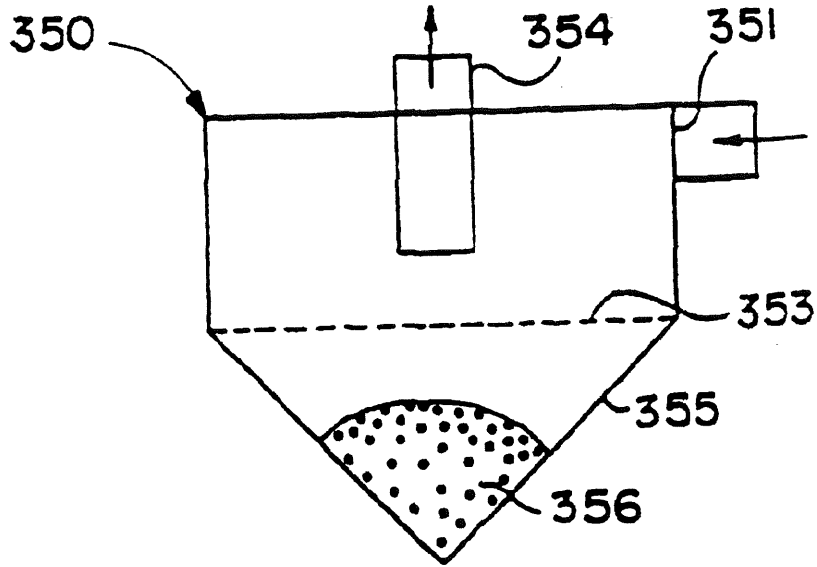

FIG. 15  
(Prior Art)

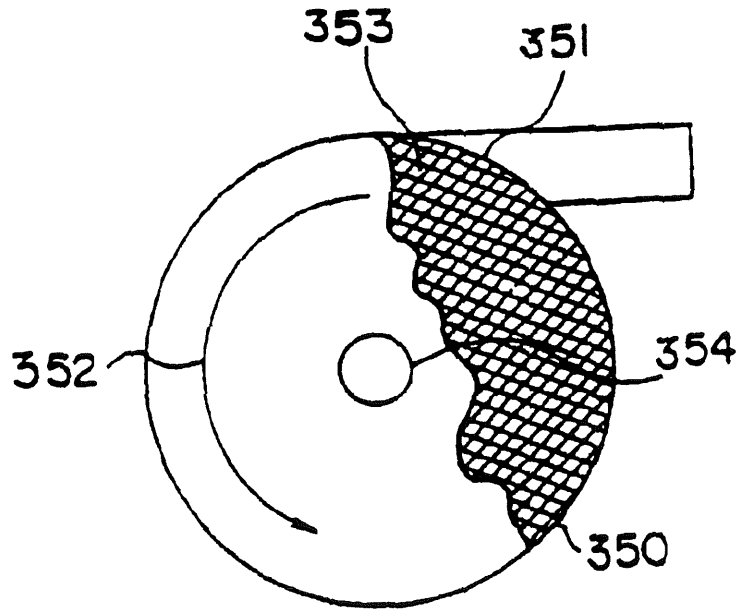
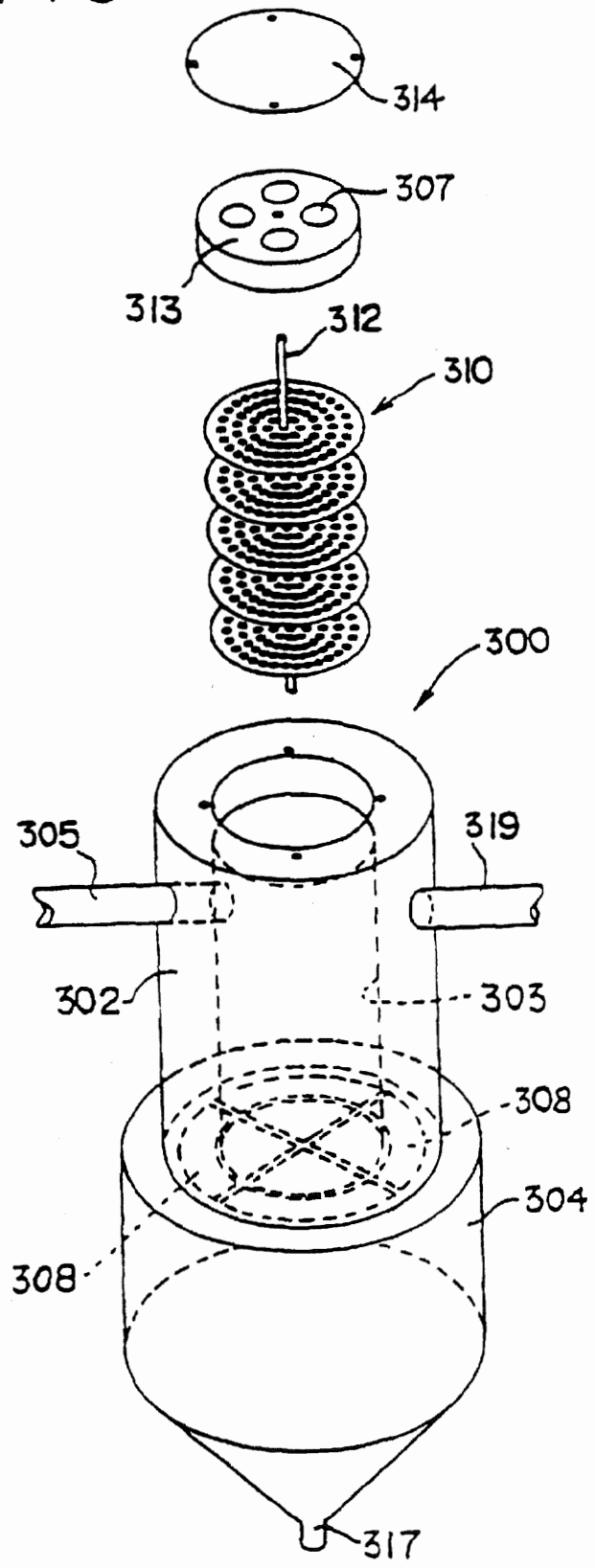

FIG. 16



## PARTICLE SUPPLY VALVE FOR USE IN BLASTING APPARATUS

This is a Divisional of application Ser. No. 08/564,290 filed Dec. 21, 1995, now U.S. Pat. No. 5,800,246, which is a national stage of PCT/JP95/00800 filed on Apr. 24, 1995.

### FIELD OF THE INVENTION

The present invention relates to a blasting apparatus, and in particular relates to a pressured tank apparatus for supplying abrasive particles in a nozzle of a blasting apparatus. Further, the present invention is also directed to a method of switching the pressured tank apparatus, a particle supply valve which opens or closes to respectively create or terminate a flow of particles and compressed air to a nozzle of a blasting apparatus, and a particle separator that extracts only reclaimable particles from a mixture of used particles and dust which have been produced during the blasting process.

### BACKGROUND ART

In the conventional blasting apparatuses, a pressured tank apparatus that supplies abrasive particles to a nozzle is constructed from a pressured tank as shown in FIG. 6, which is so called as a single direct-pressure type. In the drawing, the reference numeral 51 denotes such a pressured tank. On the pressured tank 51, there is provided a hopper 52. Between the pressured tank 51 and the hopper 52, there is provided a particle supply valve 56. The particle supply valve 56 is a pressure type shutoff valve which opens and closes automatically in accordance with the internal pressure of the pressured tank 51.

Further, connected to the top portion of the pressured tank 51 are an air supply pipe 55, which supplies air for the purpose of pressurizing the inside of the pressured tank 51, and an exhaust pipe 58 which exhausts the pressurized air within the pressured tank 51. For performing these functions, the air supply pipe 55 is provided with an air supply valve 54, and the exhaust pipe 58 is provided with an air release valve 57.

Connected to the bottom portion of the pressured tank 51 is a delivery pipe 60 for delivering compressed air and particles to a nozzle (not shown in FIG. 6). A particle supply valve 59 is provided in the delivery pipe 60. In the drawing, the reference numeral 53 denotes particles accumulated within the pressured tank 51.

Now, when the above described conventional blasting apparatus is to be used, first a prescribed amount of particles are supplied to the pressured tank 51 from the hopper 52. Then the exhaust valve 57 is closed and the air supply valve 55 is opened to allow pressurized air to pass into the pressured tank 51, whereby the pressure inside the pressured tank 51 is to be risen. As soon as the pressure inside the pressured tank 51 reaches a prescribed level, the particle supply valve 56 automatically closes, thus stopping the flow of particles 53 from the hopper 52 to the pressured tank 51 and, at the same time, preventing pressurized air from leaking into the hopper 52 from the pressured tank 51. Then when a blasting operation is to be carried out, the particle supply valve 59 is opened to allow particles to be delivered to the nozzle.

However, in the conventional blasting apparatuses, when all the particles 53 have been used up in the course of carrying out a blasting operation, the blasting operation must be suspended temporarily in order to refill the pressured tank 51 with the new particles 53. Namely, in the refilling operation, the air supply valve 54 must first be closed to stop

the flow of pressurized air into the pressured tank 41 after the blasting operation has been suspended. At the same time, the exhaust valve 57 must be opened to exhaust pressurized air out of the pressured tank 51. Then, when the pressure inside the pressured tank 51 reaches a pressure that is roughly equal to the atmospheric pressure, the particle supply valve 56 automatically opens, which then allows particles 53 to flow into the pressured tank 51 from the hopper 52. Consequently, in the conventional blasting apparatuses, a great deal of time and many tedious operations are required for refilling the pressured tank 51, and therefore blasting operation must be suspended at each refilling operation. For this reason, there is a problem in that it is impossible to carry out a continuous blasting operation with such conventional blasting apparatuses.

In order to reduce the number of such suspensions which are caused by the refilling operations as much as possible, one attempt has been made to utilize a larger pressured tank that can accommodate a great deal of particles therein. In this way, it is possible to carry out a relatively longer blasting operation with one operation of particles.

However, even with the blasting apparatuses having such larger pressured tanks, it is still necessary to suspend blasting operations in order to refill the pressured tank, and therefore it is impossible to carry out continuous blasting operation. Further, such a larger pressured tank is more dangerous in comparison with a small pressured tank, and a manufacturing cost thereof is relatively high. Furthermore, there is a problem in that a place where such a blasting apparatus having a larger pressured tank is to be installed must be limited in view of its weight and a large amount of space which is required to install such a blasting apparatus.

In view of the problems in the conventional apparatuses described above, it is a first object of the present invention to provide a compact size pressured tank apparatus for use in a blasting apparatus which enables a continuous blasting operation to be carried out, as well as a method of switching the pressured tank apparatus. Namely, in the blasting apparatus, a plurality of small pressure tanks are employed, and a pressured tank from which particles are provided to a nozzle is selected from the plurality of pressured tanks and at the same time particles are supplied or refilled to another pressured tank which is not providing particles to the nozzle.

In the meantime, in the conventional blasting apparatuses, a particle supply valve is provided for performing or terminating the supply of particles which are to be fed to the nozzle.

As one example of such conventional particle supply valves, there is known a valve of the type as shown in FIG. 9.

The known valve has a valve housing 221 provided with an inlet port 222 into which particles flow, an outlet port 223 from which the particles flow out of the valve, and a control air inlet/outlet port 224 which allows control air to flow into or out of the valve.

Further, in the valve housing 221, there are provided two diaphragms 229, 230 which are made of flexible rubber and held by the valve housing 221 to partition the space inside the valve housing 221 into a first chamber 231 and a second chamber 232. In this construction, the inlet port 222 and the outlet port 223 are communicated with the first chamber 231, and the control air inlet/outlet port 224 is communicated with the second chamber 232.

Further, a metal pin 227 is passed through the middle portion of each of the two diaphragms 229, 230 and is fixed thereto. Fixed to the end of the metal pin 227 which lies in

the first chamber 231 is a valve element 226, and fixed to the other end which lies in the second chamber 232 is a metal plate cap 228.

Now, when the valve is to stop supplying the nozzle (not shown in FIG. 9) with particles, control air is passed into the second chamber 232 through the control air inlet/outlet port 224 to pressurize the second chamber 232. This results in an increase in pressure inside the second chamber 232 which causes the flexible diaphragm 230 to deform toward the first chamber 231, which in turn causes the valve element 226 to close off the valve seat 225, thereby closing off the inlet port 222.

Then, when the valve is to be opened to supply the nozzle with particles, control air is exhausted out of the second chamber 232 through the control air inlet/outlet port 224 in order to decrease the pressure inside the second chamber 232. As a result, the diaphragm deforms toward the second chamber 232, thus causing the valve element 226 to be retracted from the shutoff position (i.e., it moves to the right side in FIG. 9). This then allows particles to flow into the first chamber 231 through the space between the valve seat 225 and the valve element 226. Thereafter, the particles flow out of the outlet port 223 and then supplied to the nozzle.

Further, the second chamber 232 is provided with an adjusting screw 233 and a handle 234 fixed to the screw 233 to allow the screw 233 to be rotated. The screw 233 is used to adjust the amount of retraction of the valve element 226 in order to adjust the amount of particles to be supplied to the nozzle. For example, when the amount of particles flowing through the valve is to be decreased, the screw 233 is rotated to increase its protruding length into the second chamber 232. In this case, the end of the metal cap 228 provided at the middle of the diaphragm 229 that has been deformed into the second chamber 232 upon the supply of the particles is come into contact with the end of the screw 233, to restrict the retraction of the valve element 226. As a result, the amount of the space between the valve element 226 and the valve seat 225 is reduced, thereby achieving a reduction in the amount of supply of particles.

However, because the diaphragms 229, 230 of the conventional valves are made of rubber, they lose elasticity during the long-term use, and this results in a problem in that leakage of particles is liable to be caused. Namely, when control air is supplied to the second chamber 232 to deform the diaphragm 230 toward the first chamber 231, it is not possible to obtain a required pressing force that pushes the valve element 226 onto the valve seat 225 if the diaphragm 230 loses its elasticity. Consequently, the valve element 226 is pushed back due to the pressure of the particles, thus leading to the leakage thereof.

Furthermore, because the rubber diaphragms 229, 230 are flexible, it is not possible to guarantee an even movement of the metal pin 227. Namely, when the supply of particles is terminated, the metal pin 227 is normally moved to the left in the drawings. However, there is a case that the pin 227 moves slightly left-downward due to the weight of the valve element 226. In this case, since the valve element 226 which is fixed to the metal pin 227 does not properly engage with the valve seat 225, there is a case that a space is created between the valve element 226 and the valve seat 225, thus resulting in a problem in that particles and compressed air are leaked through the space.

Moreover, if the power to the blasting apparatus is accidentally shut off during a blasting operation and therefore the flow of control air to the second chamber 232 suddenly stops, there is another problem in that particles and com-

pressed air are discharged from the outlet port 223. Namely, in the above condition, the valve element 226 is simply abutted onto the valve seat 225 by the restoring force of the diaphragm 229, 230, so that they are easily retracted by the pressure of compressed air and particles, thus resulting in leakage of the compressed air and particles.

In view of the above described problems, it is a second object of the present invention to provide a leakproof particle supply valve for use in a blasting apparatus which uses a piston and a biasing means in the form of a regulating spring instead of a diaphragm to avoid deterioration of flexibility characteristics.

Further, it is a third objection of the present invention to provide a particle supply valve equipped with a slide disc fixed to a valve rod to allow a seal to be maintained between a first chamber and a second chamber over a long period of time.

Furthermore, it is a fourth object of the present invention to provide a particle supply valve which can prevent leakage of pressurized air and particles from being caused, by holding the valve rod properly to close the valve seat at a predetermined position.

Moreover, it is a fifth object of the present invention to prevent discharge of pressurized air and particles which would be caused by an accident that the valve element is not retracted from the valve seat in a case where flowing and pressurizing of the control air accidentally stop during the blasting operation.

In the meantime, in blasting apparatuses, particle separators have been used for the purpose of recycling particles that have been used during a blasting process. Namely, in the blasting process, some of the particles are crushed into particle dust. However, in order to maintain a desired blasting performance, it is necessary for the particles to maintain their prescribed particle diameter. Therefore, it is necessary to provide a particle separator for removing such particle dust in order to reclaim the particles.

In the conventional apparatuses, a cyclone type particle separator is used as such particle separator. This particle separator separates reclaimable particles from particle dust and the like by utilizing a revolving air current which produces a centrifugal force. This utilizes the character that particle dust has a relatively small diameter rather than a prescribed particle and therefore the mass of the particle dust is smaller than that of the reclaimable particles.

In this connection, FIG. 14 is a longitudinal sectional side view of such a cyclone type particle separator, and FIG. 15 is a top plane view thereof.

In FIG. 14 the reference numeral 350 denotes a separating chamber. In the separating chamber 350, there is provided with an inlet port 351 which sucks a mixture of used particles and particle dust produced by a blasting process together with compressed air. Further, an exhaust port 354 is provided in a central portion of the separating chamber 350 in such a manner that it passes through the upper surface of the separating chamber 350.

Now, when the mixture of used particles and particle dust produced by a blasting process and compressed air are sucked into the inside of the separating chamber 350 through the inlet port 351, they form a revolving flow that valve seat in the direction indicated by the arrow 352 shown in FIG. 15. Then, due to the relatively large mass of each of such prescribed diameter reclaimable particles and the centrifugal force produced by such revolving flow, the reclaimable particles slowly move down toward the bottom of the separating chamber 350 as they flow in the vicinity of the



5

inner circumferential side walls of the separating chamber 350. Upon reaching the bottom of the separating chamber 350, the reclaimable particles are collected in a hopper tank 355.

In this case, the unreclaimable particle dust flows more toward the center of the separating chamber 350 due to their relatively low mass. Consequently, such low-mass particle dust gets sucked out of the separating chamber 350 together with compressed air through the exhaust port 354, and then fed to a dust collector.

In FIGS. 14 and 15, a metal screen indicated by the numeral 353 is provided for preventing peeled coating or bits of paint which have a relatively large size and has been discharged during the blasting process with being mixed into the reclaimable particles. This is because there is a case that such peeled coating or bits of paint falls into the hopper tank 355 without being discharged from the discharge port.

However, because such conventional particle separators do not have any obstructive member inside the separating chamber for diffusing the mixture of reclaimable particles and particle dust, a mixture of large and small mass particles and particle dust is caused to flow in the vicinity of the inner circumferential side walls of the separating chamber 350 when the particle separator is in actual operation, thus rendering such centrifugal separation ineffective. Furthermore, it is not possible to achieve a sufficient centrifugal separation with such conventional separators because the mixture of reclaimable particles and particle dust either falls into the hopper tank 355 or is sucked out through the exhaust port 354 before the mixture has flowed even halfway around the inside of the separating chamber 350. For these reasons, such conventional particle separators do not perform an accurate separation of reclaimable particles and particle dust.

Furthermore, if relatively large material such as peeled coating which has been exhausted in the blasting process would enter into the separating chamber, the revolving air flow is disturbed. In the conventional apparatus, the centrifugal force required for the separation process is obtained by the stable revolving air flow, there is a problem in that such a disturbance of the revolving air flow deteriorates stable separation accuracy.

Accordingly, it is a sixth object of the present invention to provide a particle separating apparatus for use in a blasting apparatus which can achieve a highly accurate separation of particles by using a diffusion member instead of a centrifugal force, and thereby being able to have high accuracy of separation and excellence in stable particle separation accuracy.

#### DISCLOSURE OF THE INVENTION

In order to achieve the objects stated above, the pressured tank apparatus according to the present invention comprises two or more pressured tanks, and a switching member for selecting from the two or more pressured tanks one pressured tank from which particles are to be supplied to a nozzle of the blasting apparatus, wherein one pressured tank or another pressured tank from which the particles are to be supplied to the nozzle of the blasting apparatus is switched to another pressured tank or one pressured tank by operating the switching means; and particle supply valve and air release valve of one or another pressured tank are closed while an air supply valve of another or one pressured tank is opened, thereby supplying the particles in the switched pressured tank to the nozzle.

As described above, in the pressured tank apparatus according to the present invention, a pressured tank from

6

which particles are supplied to a nozzle is selected from a plurality of pressured tanks, while the other tank or tanks which are not in use are being refilled with particles, thus making it possible to carry out a continuous blasting operation.

Further, the particle supply valve according to the present invention, comprising: a valve housing having an inside space; partition wall for defining the inside space of the valve housing into a first chamber and a second chamber; a particle inlet port and a particle outlet port both provided in the first chamber; a control air inlet/outlet port provided in the second chamber; a valve rod which passes the partition wall in a slidable manner, the valve rod having a first end portion positioned in the first chamber and a second end portion positioned in the second chamber; a closure member provided at the first end portion of the valve rod; a piston fixedly mounted to the valve rod in the second chamber; and a biasing means in the form of a regulatory spring for pressing the second end portion of the valve rod.

According to the particle supply valve having the above described structure, since the particle supply valve does not use partition wall made of rubber, it is possible to avoid the deterioration in elasticity associated with such construction as used in the conventional valve. As a result, the present invention provides a particle supply valve which prevents leaking of particles and pressurized air. Further, according to above described construction, by supplying or discharging the control air, it is possible to move the piston with the use of the biasing force of the regulating spring to slide the valve rod, and thereby enabling to close or open the valve seat with the valve element precisely at a prescribed position. Further, according to the above construction, in the event that the power source is erroneously or accidentally shut off during the blasting operation to terminate that control air flows into the second chamber and pressurize it, the valve element is not retracted from the valve seat because the biasing means pushes the valve rod. Therefore, even in such a case, it is possible to prevent the compressed air and particles from being ejected from the outlet port.

Further, a slide disc may be fixed to the valve rod within the first chamber. By doing so, it is possible to prevent particles from entering into sliding surfaces between the insertion hole and the valve rod, thus making it possible to maintain an airtight seal between the first chamber and the second chamber over a long period of time.

Furthermore, the particle separator for use in the blasting apparatus according to the present invention comprises: a separating chamber; an intake port for blowing reclaimable particles and particle dust obtained after the blasting operation into the separating chamber; a diffusion member for diffusing the reclaimable particles and particle dust; an exhaust port for exhausting the particle dust and compressed air; and a reclaimable particle accommodating tank disposed below the diffusion member.

According to the particle separator having the above described structure, since the reclaimable particle and particle dust are efficiently diffused by the diffusion member, it is possible to improve the separation accuracy. Further, since centrifugal force caused by rotating air flow is not used, it is possible to obtain stable separation accuracy.

#### BRIEF DESCRIPTION OF THE DRAWINGS

FIG. 1 is a sectional view of one embodiment of a blasting apparatus according to the present invention, which shows process for supplying particles to first and second pressured tanks;

FIG. 2 is a sectional view of the embodiment of the blasting apparatus according to the present invention, which shows the condition in which particles are supplied to a nozzle from the first tank to carry out a blasting operation;

FIG. 3 is a sectional view of the embodiment of the blasting apparatus according to the present invention, which shows the condition in which reclaimable particles or the like are fed from a blasting operation chamber to a particle separator by using compressed air;

FIG. 4 is a sectional view of the embodiment of the blasting apparatus according to the present invention, which shows the condition that the particles are supplied to the nozzle from the second tank, while particles are supplied to the second tank;

FIG. 5 is a time chart for the pressured tank apparatus of the embodiment shown in FIGS. 1 to 4, and it shows a sequence process in the apparatus;

FIG. 6 is a sectional view of the convention pressured tank apparatus;

FIG. 7 is a cross-sectional view which shows the condition in which an inlet of one embodiment of a particle supply valve according to the present invention is closed;

FIG. 8 is a cross-sectional view which shows the condition that the inlet of the particle supply valve shown in FIG. 7 is opened;

FIG. 9 is a cross-sectional view of the conventional particle supply valve;

FIG. 10 is a longitudinal sectional side view of a particle separator for use in an embodiment of the blasting apparatus according to the present invention;

FIG. 11 is a transverse sectional view of the particle separator shown in FIG. 10;

FIG. 12 is a perspective view of a diffusion member of the particle separator shown in FIG. 10;

FIG. 13 is a perspective view of a diffusion member of another embodiment of the particle separator according to the present invention;

FIG. 14 is a side view which shows a particle separator of the conventional cyclone type;

FIG. 15 is a top plan view of the particle separator shown in FIG. 14; and

FIG. 16 is an exploded perspective view of the particle separator shown in FIG. 10.

#### DETAILED DESCRIPTION OF THE PREFERRED EMBODIMENTS

With reference to the drawings, a detailed description of the preferred embodiments will now be given below.

FIGS. 1-4 are sectional views of a blasting apparatus equipped with a pressured tank apparatus according to the present invention. The blasting apparatus is comprised of a pressured tank apparatus, a blasting chamber and a particle separator, which are described below in that order.

The pressured tank apparatus includes two pressured tanks **1, 11** acting as a particle storage means. Each of the first and second pressured tanks **1, 11** is made from a cylindrically shaped member having upper and lower flanges and top and bottom cover plates which are fastened to the upper and lower flanges with bolts and nuts, respectively. Connected to the top cover plates of the pressured tanks **1, 11** are air supply pipes **2, 12** for supplying pressurized air to the pressured tanks **1, 11**, exhaust pipes **4, 14** for discharging pressurized air out of the pressured tanks **1, 11**, and particle supply pipes **6, 16** for supplying particles from

a hopper **304** to the pressured tanks **1, 11**. Further, air supply valves **3, 13** are provided in the air supply pipes **2, 12**, air release valves **5, 15** are provided in the exhaust pipes **4, 14**, and particle supply valves **7, 17** are provided in the particle supply pipes **6, 16**, respectively. Connected to the bottom cover plates of the pressured tanks **1, 11** are particle discharge pipes **9, 19** for discharging particles out of the pressured tanks **1, 11**, and connected to the particle discharge pipes **9, 19** is a directional control valve **20**.

In this arrangement, the air supply valves **3, 13**, the air release valves **5, 15**, the particle supply valves **7, 17** and the directional control valve **20** are controlled by a hand-operated switch (not shown in the drawings) for selecting one of the pressured tanks **1, 11** to which particles are to be supplied. In this connection, it is preferred that the switching operations of the particle supply valves **7, 17** be carried out after the switching operations of the air supply valves **3, 13**, exhaust valves **5, 15** and directional control valve **20** have been completed. To accomplish this, a timer (now shown in the drawings) may be provided to delay a prescribed length of time the switching operations of the particle supply valves **7, 17**, when the hand-operated switch is operated to carry out the switching operations. Connected to the directional control valve **20** is a delivery pipe **23** provided with a particle supply valve **200**. This particle supply valve **200** is cooperatively connected to a nozzle switch (not shown in FIGS. 1 to 4). In this regard, it should be understood that the particle supply valve **200** may be constructed from a conventional particle supply valve having partition walls made of rubber. However, if such is done, there is a possibility that leakage would occur due to the deterioration of the elasticity of the rubber. Furthermore, a pipe indicated by the reference numeral **22** is a pressured air supply pipe, which is connected to the delivery pipe **23** to add highly pressurized air to the compressed air and particles passing through the delivery pipe **23**.

The blasting chamber is comprised of an operation chamber **25** and a hopper **26** provided at the bottom of the operation chamber **25**. Provided inside the operation chamber **25** for carrying out blasting operations is a nozzle **24** provided at the tip of the delivery pipe **23**. At the bottom of the hopper **26**, particle ejected from the nozzle **24** are to be accumulated, which include reclaimable particles, particles of dust which are produced from some particles that have been crushed during the blasting operation and peeled coating or flake of paint. Connected to the bottom of the hopper **26** is a delivery pipe **29** for delivering the substances that have accumulated at the bottom of the hopper **26** as described above to the separator **300**. In this connection, the delivery pipe **29** is provided with a particle delivery valve **27** which is connected to the bottom of the hopper **26**. Further, a pipe indicated by the reference numeral **28** is a pressurized air supply pipe **28** which is connected to the particle delivery valve **27** for supplying highly pressurized air to the delivery pipe **29** in order to force reclaimable particles and particles of dust to the separator **300** through the delivery pipe **29**. Also, provided in the hopper **26** is a level sensor (not shown in the drawings) which sends a signal to a control device (not shown in the drawings) when the amount of used particles, etc. accumulated in the hopper **26** reaches a predetermined volume. In this connection, upon receiving a signal from the level sensor, the control device is operated so as to open the particle delivery valve **27** to supply the highly pressurized air through the air supply pipe **28**, thereby delivering used particles, etc. to the particle separator **300**.

The particle separator **300** is an apparatus for separating reclaimable particles from particle dust, etc. As shown in

FIG. 1, the particle separator 300 is comprised of a cylindrically shaped outer chamber 302, a cylindrically shaped separating chamber 303 concentrically arranged within the outer chamber 302, and a hopper tank 304 arranged below the separating chamber 303 to collect reclaimable particles. The delivery pipe 29 is connected to an upper portion of the cylindrical wall of the separating chamber 303 to allow reclaimable particles, particle dust, etc. produced during a blasting process to be passed together with compressed air from the delivery pipe 29 into the separating chamber 303. Further, a first exhaust opening 307 is provided in a top portion of the separating chamber 303, and five diffusion plates 311a, 311b, 311c, 311d and 311e are arranged inside the separating chamber 303. The diffusion plates 311a, 311b, 311c, 311d and 311e are made of a punched metal, respectively and they are mounted on a supporting rod 312 in such a manner that they are spaced through a predetermined interval. The diffusion plates 311a-311e have already roughly the same diameter as that of the separating chamber 303. In this connection, the arrangement of the supporting rod 312 and the diffusion plates 311a-311e is removable from the outer chamber 302 by opening an outer cover 314 provided at the top of the outer chamber 302 and pulling such arrangement out of the separating chamber 303. Further, a second exhaust opening 308 is formed in the upper part of the hopper tank 304 and particle supply pipes 6, 16 are connected to the bottom of the hopper tank 304. Connected to the right side of the outer chamber 302 is an exhaust pipe 319 for sucking out particle dust, etc. and sending such particle dust to a dust collector (not shown in the drawings).

Furthermore, it is possible to use a commonly known cyclone type separator in place of the inventor's proposed particle separator described above. In this regard, it should be noted that because such cyclone type separators lack a particle diffusion means, and separation of reclaimable particles and dust is carried out only by utilizing centrifugal force, a mixture of particles and dust are liable to fall into the hopper. Therefore, the cyclone type separators have relatively poor separation efficiency in comparison with the inventor's proposed particle separator.

Hereinbelow, the operation of the blasting apparatus according to the present invention will be described with reference to FIGS. 1-4.

First, particles are supplied to the hopper 26 of the blasting chamber. When the volume of particles in the hopper 26 reaches a prescribed level, the level sensor sends a signal to the control device. Upon receiving such signal, the control device opens the particle delivery valve 27 and activates a device to supply pressurized air through the air supply pipe 28 to force these particles to be delivered to the particle separator 300 through the delivery pipe 29. The particles which are delivered to the particle separator then flow into the separating chamber 303 where they pass through the holes in the punched metal diffusion plates 311a-311e and fall into the hopper 34. At this point in the process, there is no need to activate the dust collector, because the particles reaching the particle separator 300 from the hopper tank 26 have not yet been used for carrying out a blasting operation, and therefore not mixed with dust or flake of paint. Now, after falling into the hopper 34, the particles pass into the particle delivery pipes 6, 16 and through the particle supply valves 7, 17, which are both open at this time, and then fall into the first and second pressured tanks 1, 11 at approximately the same amount. While this filling process is being carried out, the air release valves 5, 15 are kept open, the air supply valves 3, 13 are kept closed,

and the particle supply valve 200 is also kept closed to prevent particles from leaking into the particle delivery pipe 23 (See FIG. 1).

Next, after a prescribed amount of particles have been supplied to the first and second pressured tanks 1, 11, the directional control valve 20 is switched to the side of the first pressured tank 1 by operating a changeover switch (not shown in the drawing). In this case, it should be noted that in a case where the directional control valve 20 has been already switched to the side of the first pressured tank 1, the directional control valve 20 is not operable even when the changeover switch is operated. At the same time, the operation of the changeover switch causes the particle supply valve 7 and the air release valve 5 to close, and the air supply valve 3 to open to allow compressed air to flow into the second pressured tank 11 in order to pressurize the inside of the first pressured tank 1. At this point, the preparations needed for carrying out a blasting operation are completed. In this connection, FIG. 5 is a diagram which shows the open/closed states for each valve, wherein the step of preparing a blasting operation is indicated by "Start A".

Now, when a blasting operation is to begin, a nozzle switch (not shown in the drawings) is operated to open the particle supply valve 200 to allow particles and compressed air from the first pressured tank 1 to pass through the particle discharge pipe 9 and the particle delivery pipe 23. Upon reaching the end of the particle delivery pipe 23, the particles are ejected out of the nozzle 24 together with the pressurized air. In this connection, because the pressurized air that passes out of the pressured tank 1 together with the discharged particles may not have sufficient force to create an adequate blasting force from the nozzle 24, the compressed air supply pipe 22 is activated to add highly pressurized air (2-5 kg/cm<sup>2</sup>) to the particles and compressed air passing through the particle delivery pipe 23 from the first pressured tank 1 (see FIG. 2).

As the blasting operation continues, the amount of particles contained in the first pressured tank steadily decreases. At the same time, there is a steady piling up of used particles and particle dust, bits of paint, etc. in the hopper 26 of the blasting chamber. Now, when the volume of used particles and particle dust in the hopper 26 reaches a prescribed level, the level sensor sends a signal to the control device. Upon receiving such signal, the control device opens the particle delivery valve 27 and activates a device to supply pressurized air through the air supply pipe 28 to force the reclaimable particles and the like to be delivered to the particle separator 300 through the delivery pipe 29 (see FIG. 3). The beginning of this operation is indicated by "Level Sensor ON (1)" shown in FIG. 5.

As the reclaimable particles, particle dust and bits of paint are being transported to the particle separator 300 through the delivery pipe 29, a dust collector (not shown in the drawings) which is connected to the exhaust pipe 319 is activated. Consequently, a negative pressure is created in the outer chamber 302, and this causes the usable particles and particle dust and the like approaching the end of the delivery pipe 29 to be suddenly sucked into the separating chamber 303. The reclaimable particles and particle dust that have entered into the separating chamber 303 then strike onto the inner walls of the separating chamber 303 and the top surface (the particle reception surface) of the uppermost diffusion plate 311a at high velocity, and then they become dispersed. At this time, because the particle dust has a smaller mass than the blasting particles, it gets sucked out of the separating chamber 303 through the exhaust opening 307. Then, it is discharged to the dust collector through the

## 11

space defined between the outer upper surface of the separating chamber 303 and the bottom surface of the outer cover 314 of the outer chamber 302, and through the exhaust pipe 319. Thereafter, the more massive reclaimable particles and the particle dust that do not get sucked out through the exhaust opening 307 pass through the punched holes in the diffusion plate 311a and fall onto the top of the diffusion plate 311b and then strike onto the top surface of the diffusion plate 311b to be dispersed. At this time, any relatively low mass particle dust that is present will be dispersed upwardly to pass through the punched holes in the diffusion plate 311a, and then it is sucked out of the exhaust opening 307. Then the reclaimable particles and the particle dust that have fallen onto the top of the diffusion plate 311c through the punched holes of the diffusion plate 311b are further separated in the same manner as was described in connection with the diffusion plate 311b. This process continues until the reclaimable particles pass through the punched holes in the bottommost diffusion plate 311e, at which point the reclaimable particles including a small amount of dust fall into the hopper 34. At this time, any relatively low mass particle dust that is still present is sucked up through the second exhaust opening 308 and the space defined between the outer wall of the separating chamber 303 and the inner wall of the outer chamber 302, and then it is discharged to the waste collector through the exhaust pipe 319. While this whole process is taking place, the relatively small bits of paint or coating are discharged from the exhaust pipe 319. On the other hand, however, the relatively large bits of paint or coating that cannot pass through the punched holes of the diffusion plates 311a-311e remain on the tops of the diffusion plates 311a-311e. To remove these large bits of paint, the outer cover 314 of the outer chamber 302 is opened after the blasting apparatus is turned off, and then the supporting rod 312 and the diffusion plates 311a-311e fixed thereto are removed from the outer chamber 302, thereby enabling to remove the large bits of paint easily.

Now, when the first pressured tank 1 runs out of particles, the directional control valve 20 is switched from the first pressured tank 1 to the second pressured tank 11 by operating the changeover switch. At the same time, the operation of the changeover switch causes the particle supply valve 17 and the air release valve 15 to close, and the air supply valve 13 to open to allow pressurized air to flow into the second pressured tank 11 in order to pressurize the inside of the second pressured tank 11. By carrying out the above operation, a tank from which particles are supplied to the nozzle 24 is changed from the first pressured tank 1 to the second pressured tank 11 (see FIG. 4). This is indicated by "B Switching" in FIG. 5.

At the same time, the operation of the changeover switch to the second pressured tank 11 causes the air supply valve 3 to close and the air release valve 5 to open in order to lower the pressure inside the first pressured tank 1 to a level roughly equal to the atmospheric pressure. Next, by means of a timer (not shown in the drawings), the particle supply valve 7 is opened to supply particles from the hopper 34 to the inside of the first pressured tank 1 a prescribed amount of time after the operations of the directional control valve 20, the air supply valve 3 and the air release valve 5 have been carried out. In this connection, it should be understood that such delay of the operation of the particle supply valve 7 by the timer assures that particles are supplied to the first pressured tank 1 from the hopper 34 only after the pressure inside the first pressured tank 1 has reached a level roughly equal to the atmospheric pressure in order to prevent pressurized air from leaking into the hopper 34.

## 12

Accordingly, by repeatedly carrying out the above described operation of the changeover switch, it becomes possible to continuously supply particles in either of the first pressured tank 1 or second pressured tank 11 to the nozzle 24.

In this connection, it should be noted here that the present invention is not limited to the provision of two pressured tanks as described in the embodiment above. Instead, it is also possible to employ three or more pressured tanks in the pressured tank apparatus according to the present invention. Furthermore, it is possible to employ an arrangement of two or more tanks having different capacities in the pressured tank apparatus according to the present invention. For example, in the embodiment described above, one of the pressured tanks 1, 11 may be a large main tank while the other is a smaller subtank which is used only during refilling operation of particles to the main tank.

As was stated previously above, the pressured tank apparatus according to the present invention, a tank from which particles are supplied to a nozzle is selected from a plurality of pressured tanks, while the remaining tank or tanks which are not in use are being refilled with particles, thus making it possible to carry out a continuous blasting operation in which no suspension is required for refilling particles.

Further, as it is possible to utilize a plurality of small pressured tanks in the pressured tank apparatus according to the present invention, a high degree of safety can be achieved and the overall size of the blasting apparatus can be kept to a minimum. As a result, manufacturing costs can be kept down and only a small amount of space is required to install the blasting apparatus.

Furthermore, when a predetermined amount of particles is supplied to the blasting chamber, it is detected by the level sensor. When such detection is made, the particles are fed to the particle separator which particles are being supplied to the other tank or tanks which is not in use. Therefore, it is possible to save the time required to refill particles to the tank, which makes it possible to carry out continuous blasting operation.

Moreover, since it is possible to use the reclaimable particles in the blasting chamber, it is not necessary to refill new particles from an upper portion of a pressured tank which is normally put at relatively a high position.

Next, with reference to FIG. 7 and FIG. 8, a detailed description of the preferred embodiment of the particle supply valve 200 according to the present invention will now be given below.

FIG. 7 is a cross-sectional view of a particle supply valve 200 according to the present invention, in which the valve 200 is shown in an open state. FIG. 8 is a cross-sectional view of the same valve 200 shown in FIG. 7, in which the valve 200 is shown in a closed state.

As shown in FIGS. 7 and 8, the particle supply valve 200 has a valve housing 201 made of brass. The valve housing 201 is provided with an inlet port 202 which allows particles and pressurized air to pass into the valve, an outlet port 203 which allows particles and pressurized air to pass out of the valve, and a control air inlet/outlet port 204 which allows control air to be supplied to and released from the valve.

Further, a brass partition wall 210 is integrally formed inside the valve housing 201 to partition the space inside the valve housing into a first chamber 215 and a second chamber 216. The inlet port 202 and the outlet port 203 are communicated with the first chamber 215, and the control air inlet/outlet port 204 is communicated with the second chamber 216.

Further a valve rod 207 which is also made of brass is slidably inserted through an insertion hole 211 formed in the central portion of the partition wall 210. Provided on the tip end of the left side portion of the valve rod 207 which lies in the first chamber 215 is a hard rubber valve element 206. The hard rubber valve element 206 is formed in the shape of a half sphere. By being tied to the valve rod 207, the valve element 206 is movable to seal off an valve seat 205 of the inlet port 202 in order to shut off the supply of particles and pressurized air flowing into the first chamber 215 of the particle supply valve 200. To accomplish this function, the valve element 206 is preferably formed to have a diameter that is larger than the diameter of the valve seat 205.

Also, on the side of the valve rod 207 which lies in the first chamber 215, there is provided a brass slide disc 209 which is fixed to the valve rod 207. The slide disc 209 is formed such that the outer circumferential surface thereof is in sliding contact with the inner circumferential wall surface of the first chamber 215. As a result, the slide disc 209 makes it possible to divide the first chamber 215 into a first space which receives particles and pressurized air and a second space which is kept free of particles and pressurized air.

Further, on the side of the valve rod 207 which lies in the second chamber 216, there is provided a brass piston 208 which is fixed to the valve rod 207. The outer circumferential surface of the piston 208 is in sliding contact with the inner circumferential surface of the second chamber 216. The circumferential surface of the piston 208 is widened to stabilize the sliding movement of the valve rod 207 and to provide a highly effective airtight seal against the control air under pressure in the second chamber 216. Further, a hard rubber shock absorber 217 is provided in the second chamber 216 on the wall surface of the partition wall 210.

Further, a biasing means 212 comprised of a metal spring is provided in the second chamber 216 between a protruding portion formed with an end portion of the valve rod 207 which lies in the second chamber 216 and the inner wall surface of the second chamber 216 which directly faces the protruding portion of the valve rod 207. In particular, one end of the biasing means 212 is secured around the protruding portion of the valve rod 207 and the other end of the biasing means 212 is secured inside an annular fixing member or spring retainer 213 provided on the inner wall surface of the second chamber 216. Further, an adjusting screw 214 is inserted through the valve housing 201 in a manner that allows an end portion thereof to be screwed into the second chamber 216. Moreover, the adjusting screw 214 has a head portion lying outside the valve housing 201 which can be turned to adjust the length of the end portion thereof protruding within the second chamber 215.

Now, when the supply of particles and compressed air to a nozzle 24 (shown in FIG. 1) is to be shut off, as shown in FIG. 7, control air is passed into the second chamber 216 through the control air inlet/outlet port 204 to pressurize the second chamber 216, thereby causing the piston 208 to be pushed toward the first chamber 215, and this in turn causes the valve rod 207 to slide to the left, whereby the valve element 206 is formed into the valve seat 205 to seal off the inlet port 202.

On the other hand, when particles and compressed air are to be supplied to the nozzle 24, the control air in the second chamber 216 is released through the inlet/outlet port 204 to depressurize the second chamber 216, thereby causing the piston 208 to retract in a direction away from the first chamber 215, and this in turn causes the valve rod 207 to slide to the right, whereby the valve element 206 is pulled

out of the valve seat 205 (i.e., the valve element 206 moves to the right in FIG. 8). As a result, particles and pressurized air first flow from the inlet port 202 into the first chamber 215 through the space created between the valve seat 205 and the valve element 206, and then flow out through the outlet port 203 to be supplied to the nozzle.

In this connection, because the slide disc 209 divides the first chamber 215 into the first space which receives particles and the second space which is kept free of particles, it is possible to prevent particles from entering into the space between the insertion hole 211 and the valve rod 207. As a result, it is possible to prevent the sliding surfaces from being abraded by the particles.

Further, by turning the adjusting screw 214 to increase the protruding length of the end portion thereof inside the second chamber 216, it is possible to reduce the distance between the left end of the adjusting screw 214 and the right end of the valve rod 207, and this distance defines the retraction distance of the valve element 206. Namely, as shown in FIG. 8, when particles and compressed air are being supplied to the nozzle, the left end of the adjusting screw 214 is in contact with the right end of the valve rod 207. Consequently, it is possible to control the amount of particles and compressed air being supplied to the nozzle by turning the adjusting screw 214 to adjust the length of the end portion inside the second chamber 216.

Furthermore, because the valve housing 201, partition wall 210, valve rod 207, piston 208 and slide disc 209 are made of brass, they have a higher hardness than the particles. As a result, the valve is imparted with excellent antiabrasion characteristics.

Moreover, because the wall surface of the partition wall 210 that lies inside the second chamber 216 is provided with the hard rubber shock absorber 217, it is possible to prevent the piston 208 from colliding with the partition wall 210, and this makes it possible to prevent the valve element 206 from being damaged when the second chamber 216 experiences a sudden rise in pressure.

In summary, because the particle supply valve according to the present invention does not use partition walls made of rubber, it is possible to avoid the deterioration in elasticity associated with such construction. As a result, the present invention provides a particle supply valve which prevents leakage of particles and compressed air.

Furthermore, because the partition wall, sliding wall and piston enable the valve rod to maintain its sliding characteristics, it is possible to consistently carry out a proper sliding operation with the valve rod. As a result, the valve element fixed to the valve rod can consistently be moved into a prescribed position in the opening, thus making it possible to prevent particles and pressurized air from leaking through the valve seat.

Moreover, because the valve rod is held slidably by means of the partition wall, the slide disc and the piston, it is possible to always carry out precise sliding movement. Therefore, the valve element fixed to the valve rod can be brought into contact with the opening at a prescribed position, thereby preventing leaking of pressurized air and particles.

Furthermore, in the event that the power source is erroneously shut off during the blasting operation to terminate that control air flows into the second chamber and pressurize it, the valve element is not retracted from the opening because the biasing means pushes the valve rod. Therefore, even in such a case, it is possible to prevent the pressurized air and particles from being ejected from the outlet port.

Moreover, since the slide disc inside the first chamber, it is possible to prevent particles from entering into the sliding surfaces between the insertion hole and the valve rod, thus making it possible to maintain an airtight seal between the first chamber and the second chamber over a long period of time.

Moreover, the amount of particles to be supplied can be adjusted by the operation of the adjusting screw.

Hereinafter, with reference to FIG. 10 and FIG. 11, a detailed description of a first embodiment of the particle separator 300 according to the present invention will now be given below.

In this connection, FIG. 10 is a cross-sectional side view of a particle separator according to the present invention, and FIG. 11 is a top plan view thereof. As shown in these figures, the particle separator 300 includes a cylindrically shaped outer chamber 302, a cylindrically shaped separating chamber 303 arranged inside the outer chamber 302, and a hopper tank 304 arranged below the separating chamber 303 to collect reclaimable particles.

Provided in an upper portion of the circumferential wall of the separating chamber 303 is an inlet port 306 which allows a mixture of reclaimable particles and particle dust produced by a blasting operation to be fed together with pressurized air to the inside of the separating chamber 303. As shown in FIG. 11, the inlet port 306 faces toward the central portion of the upper section of the separating chamber 303. In this connection, because the present invention does not utilize a rotating flow of air, it is possible to provide a plurality of inlet ports 306. Further, the top of the separating chamber 303 is provided with an inner cover 313 which has four first exhaust valve seats (ports) 307 formed therein (see FIG. 11).

Inserted into the inside of the separating chamber 303 is a diffusion member 310. The diffusion member 310 is supported by a stay 315 at a lower portion thereof. The diffusion member 310 can be removed from the outer chamber 302 by opening the inner cover 313 and the outer cover 314.

The diffusion member 310 includes five circular-shaped punched metal diffusion plates 311a, 311b, 311c, 311d, 311e which are spaced a prescribed distance from each other and a diffusion plate support member 12 which passes through a central portion of the respective diffusion plates 311a-311e to support the diffusion plates 311a-311e. FIG. 12 is a perspective view of the diffusion member 310. As shown in FIG. 12, the five diffusion plates 311a-311e are spaced an equal distance from each other in a layered arrangement that is fixed to the diffusion plate support member 312.

In this connection, the diameter of each hole of the punched metal diffusion plate is set in accordance with the diameter of the reclaimable particles. For example, based on experiments carried out by the present inventor, it was determined that holes having a diameter of 3 mm was preferred for reclaimable particles having a diameter of 0.8 mm.

Further, four second exhaust valve seats (ports) 308 are formed in the top of the hopper tank 304 and a particle discharge outlet 317 is provided at the bottom of the hopper 304.

Further, a delivery pipe 305 passes through the outer chamber 302 from the left side of FIG. 10, whose blowing port 306 is opened in the separating chamber 303. The delivery pipe 305 is connected to the blasting apparatus (not shown in the drawing) to deliver a mixture of reclaimable particles and particle dust together with compressed air. Further, on the right side of the outer chamber 302, a dust discharge port 318 is formed, to which an exhaust pipe 319 which sends particle dust to a dust collector (not shown in the drawings) is connected.

Now, the operation sequence of the above-described particle separator 300 will be given below. First, a mixture of reclaimable particles and particle dust produced by a blasting operation is delivered to the inside of the separating chamber 303 together with compressed air through the delivery pipe 305. In this case, the dust collector (not shown in the drawings) is activated to create a negative pressure inside the separating chamber 303. Therefore, the mixture of reclaimable particles and particle dust which have entered the inside of the separating chamber 303 from the inlet port 306 strike onto the inner walls of the separating chamber 303, the bottom surface of the inner cover 313 and the top surface of the uppermost diffusion plate 311a (the particle reception surface) at high velocity and thereby being dispersed over the top surface of the diffusion plate 311a. At this time, because the particle dust has a smaller mass than the reclaimable particles, the particle dust gets sucked out of the separating chamber 303 through the first exhaust openings 307 and passes through the upper space defined between the upper surface of the separating chamber 303 and the bottom surface of the outer cover 313 of the outer chamber 302, and then they are discharged from the dust exhaust port 318 to the dust collector via the exhaust pipe 319.

At this point, the more massive reclaimable particles and the particle dust that did not get sucked out through the first exhaust openings 307 pass through the punched holes in the diffusion plate 311a and fall onto the top of the diffusion plate 311b to be dispersed. At this time, any relatively low mass particle dust that is present will be sucked upwards again to pass through the punched holes in the diffusion plate 311a and out of the first exhaust openings 307. On the other hand, the reclaimable particles and particle dust that fall onto the diffusion plate 311c through the punched holes of the diffusion plate 311b are separated again in the same manner described above.

This process continues until the reclaimable particles and the remaining particle dust pass through the punched holes in the bottommost diffusion plate 311e, at which point they fall into the hopper tank 304. At this time, any relatively low mass particle dust that is still present is sucked up through the second exhaust openings 308 and the space defined between the outside walls of the separating chamber 303 and the inside walls of the outer chamber 302, and then they are discharged through the exhaust port 318.

Now, as was described for the present embodiment, in addition to the first exhaust openings 307, the separating chamber 303 is provided with the second exhaust openings 308 to allow the particle dust and compressed air that have passed through the diffusion member 310 to be sucked up and expelled out through the exhaust port 318. As a result, the particle separator 300 of this embodiment has an additional step for removing particle dust. This prevents any particle dust from being mixed with the reclaimable particle, which is advantageous to achieve a highly accurate separation.

Furthermore, in the present embodiment of the particle separator according to the present intention, the first exhaust openings 307 are arranged so as to face with the top surface of the uppermost diffusion plate 311a of the diffusion member 310. As a result, it becomes possible to easily suck out the particle dust diffused by the diffusion member 310, thus enabling the present invention to achieve a high separation accuracy.

Furthermore, in the present embodiment of the particle separator according to the present invention, the first exhaust openings 307 are arranged above the top surface of the uppermost diffusion plate 311a of the diffusion member 310. As a result, it is possible to prevent the large-mass reclaimable particles from being sucked out through the first



exhaust openings 307, and this enables the present invention to achieve an even higher separation accuracy.

Furthermore, in the present embodiment of the particle separator according to the present invention, the second exhaust openings 308 are additionally arranged in the top of the hopper tank 304. As a result, it is also possible to prevent the large-mass reclaimable particles from being sucked out through the second exhaust openings 308, and this enables the present invention to achieve an even higher separation accuracy.

Furthermore, in the present embodiment of the particle separator according to the present invention, the diffusion member 310 can be easily removed from the separating chamber 303 and the outer chamber 302 by opening the inner cover 313 and the outer cover 314. As a result, it is possible to easily remove the relatively large bits of peeled paint that remain on the tops of the respective diffusion plates 311a-311e.

Hereinafter, with reference to FIG. 13, a detailed description of a second embodiment of a particle separator 300 according to the present invention will now be given below. In this regard, FIG. 13 is a perspective view of the second embodiment of the diffusion member 340 of the particle separator according to the present invention. In this regard, the diffusion member 340 is interchangeable with the above-described diffusion member 310 of the first embodiment of the particle separator according to the present invention. Namely, in contrast with the diffusion member 310 of the first embodiment of the particle separator which utilizes five punched metal diffusion plates 311a-311e having a plurality of holes, the diffusion member 340 of the second embodiment of a particle separator utilizes an equally spaced layered arrangement of five diffusion plates 341a-341e having a plurality of slits formed therein. In this embodiment, as shown in FIG. 13, each slit plate is rotatably supported by a diffusion plate support member 342.

Now, in the arrangement shown in FIG. 13, the slits of adjacent diffusion plates are out of alignment with each other. Such an arrangement facilitates diffusion of the mixture of reclaimable particles and particle dust, which leads to increased amount of waste material sucked out through the first exhaust openings 307. However, if too much diffusion is created, some of the reclaimable particles may be mixed into the waste material and such reclaimable particles get sucked out together with the waste material to be expelled through the first exhaust openings 307. For this reason, it may be necessary to lower the degree of diffusion created by the diffusion member 340.

In this connection, it is possible to adjust the degree of diffusion created by the diffusion member 340 by rotating one or more of the diffusion plates 341a-341e to change the direction of the slits thereof with respect to the slits of adjacent diffusion plates. For example, it is possible to rotate the three diffusion plates 341a-341c in order to align the slits of the diffusion plates 341a-341c with each other. If this is done, the mixture of reclaimable particles and particle dust will easily pass through the slits of the first three diffusion plates 341a-341c and then become widely diffused at the diffusion plates 341d and 341e which are located relatively far from the first exhaust openings 307. As a result, it is possible to prevent the reclaimable particles from being sucked out through the first exhaust openings 307.

Thus, by simply rotating one or more of the diffusion plates 341a-341e, a user of the particle separator can adjust the degree of diffusion created by the diffusion member 340 in order to prevent reclaimable particles from being expelled to the dust collector.

In summary, according to the second embodiment as described above, it becomes possible to prevent the reclaimable particles from being expelled to the dust collector by adjusting the diffusion efficiency by rotating each diffusion plate appropriately.

## INDUSTRIAL UTILIZATION

As described above, a blasting apparatus according to the present invention is particularly useful, as is known, in peeling operation of paint or surface processing which are applied onto the surface of metals, resin materials or woods, and it is particularly suitable in a continuous blasting operation. Further, the blasting apparatus according to the present invention can be realized in any blasting apparatuses which include a relatively small blasting apparatus in which operation is carried out under the condition that an operator holds a nozzle directly through a protection material and a relatively large blasting apparatus which are used in outer surface processing of trains or the like.

What is claimed is:

1. A particle supply valve for use in a blasting apparatus, wherein said valve supplies abrasive particles to the blasting apparatus by means of applying pressurized air, comprising:

- a valve housing having a space inside thereof;
- a partition wall dividing the space of said valve housing into a first and second chamber each having inside walls;
- a particle inlet and a particle outlet both provided in said first chamber;
- a control air inlet/outlet port provided in said second chamber;
- a valve rod having two ends which is slidable and penetrates said partition wall to extend within each of the first chamber and the second chamber;
- a valve seat formed at the particle inlet;
- a valve element provided at one of the ends of the valve rod so as to open or close the valve seat by the sliding of said valve rod;
- a slide disc provided along a portion of the valve rod positioned within the first chamber so as to contact and slide freely along the inside wall of said first chamber;
- a piston fixedly mounted to the valve rod positioned within the second chamber for pressing said valve rod against the valve seat when pressurized air is applied through the control air inlet/outlet port;
- a shock absorber provided at a peripheral region of the partition wall positioned in the second chamber;
- an adjusting screw positioned within and through the inside wall of the second chamber which is opposite to the partition wall and shock absorber, which screw contacts the other end of the valve rod and determines maximum valve clearance of the valve seat; and
- a biasing means arranged around the valve rod positioned between the piston and the inside wall of the second chamber through which the screw is positioned.

2. The valve of claim 1, wherein the shock absorber is made from hard rubber materials.

3. The valve of claim 1, wherein the biasing means is a spring.

\* \* \* \* \*

